

## FEATURES & BENEFITS

### FIELD CONFIGURABLE FILTERING

3000 gallon (11356 L) capacity, Electronic Lifecycle Control filter cartridge. Choose between filtered or non-filtered water with the included interchangeable 3000-gallon filter and 5y rated strainer.

### AUTO PURGE

Auto purge feature automatically cycles once every 24 hours, if no use, to assure a fresh water supply as well as trap integrity.

### VANDAL RESISTANT

Vandal-resistant sensor resists scratching and water droplet fowling, and is separated from display for maintenance, and sensor features a 20-second timeout function which prevents unwanted use.

### LED DISPLAY

Display menu which shows sensor range adjustment, factory reset, software/firmware version readout and error readout, along with bottle counter showing number of bottles saved.

### MOUNTING

Heavy-duty 16-gauge galvanized steel mounting box provides a secure and quick installation, and allows enough access room for water stop, electrical junction box, filter and drain connections.

## OPTIONS

- Filter Replacement: Model 6428-C pack of twelve 3000-gallon (11356 L) replacement filters.

For more information, visit [www.hawsc.com](http://www.hawsc.com) or call (888) 640-4297.



## SPECIFICATIONS

Model 2000HSSM RIVIVE™ Hydration Station™ motion-activated bottle filling station with architectural roots is surface-mount wheel chair accessible, constructed of heavy duty, Type 304 Stainless Steel with a satin finish. The unit features an electric sensor for touch-free hygienic operation and a 20-second timeout preventing unwanted use, auto-purge after 24 of non-use, laminar flow to prevent splashing, a 1.1 gpm (4.2 L) flow rate for quick fill-up, and a 3000-gallon (11356 L) carbon block filter. Display menu shows sensor range adjustment, factory reset, software/firmware version readout and error readout. The mounting box is of heavy gauge, galvanized steel, which provides enough access room for water stop, electrical junction box, filter and drain connections. Field-configurable as either filtered or non-filtered.

## APPLICATIONS

Perfect for either public or private indoor settings, this water dispenser is a great fit in areas where aesthetics are important to the overall appeal of the architecture. Specifically, this type of surface wall-mounted bottle filling station is ideal for office buildings, airports, schools, manufacturing facilities and municipalities. This model meets the Americans with Disabilities Act when mounted at the correct height. Haws manufactures drinking fountains and electric water coolers to be lead-free by all known definitions including NSF/ANSI/CAN 61, Section 9, NSF/ANSI/CAN 372, and CSA Standard B483.1. Product is compliant to California Health and Safety Code 116875 (AB 1953-2006), California Proposition 65 and the Federal Safe Drinking Water Act.



NOTES:

1. HOLD ROUGH-IN DIMENSIONS  $\pm 1/4"$  (6.4mm).
2. WHEN INSTALLING THIS UNIT, LOCAL, STATE, OR FEDERAL CODES SHOULD BE ADHERED TO. INSTALL A TRAP IN THE WASTE LINE AND A SCREWDRIVER STOP IN THE SUPPLY LINE IF REQUIRED.

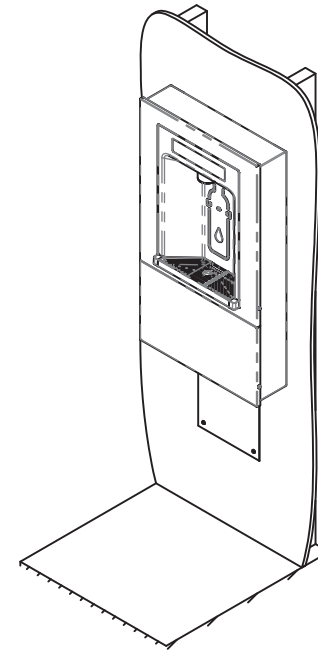
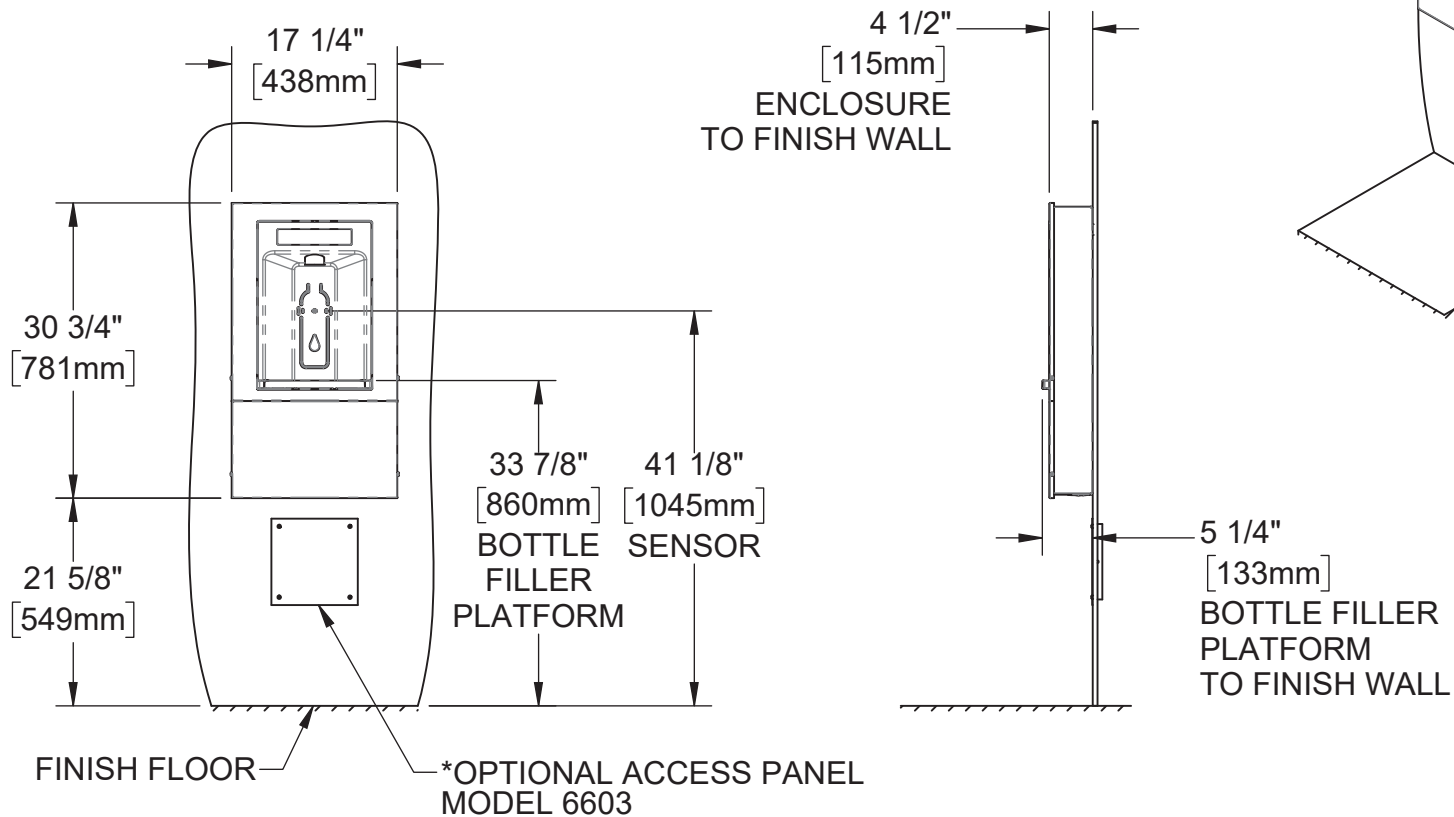

		1455 KLEPPE LANE SPARKS, NEVADA 89431 (775) 359-4712 FAX (775) 359-7424 E-MAIL: HAWS@HAWS.CO.COM WEBSITE: WWW.HAWS.CO.COM	
		ECN: 6000 DRAWN: DHP APPROVED:	REV. ECN: 6000 DATE: 08/16/23 DATE:
PART NUMBER 0510002226.D			REVISION 1
SCALE: 1:20		DRAWING TYPE: INSTALLATION	SIZE: A SHEET 1 OF 7

NOTES:

3. ROUGH IN ELECTRICAL, WASTE PLUMBING, AND WATER SUPPLY WITH DIMENSIONS SHOWN.
4. INSTALL 120V AC (60HZ) 15-AMP GFCI-PROTECTED OUTLET (NOT SUPPLIED) IN SPECIFIED LOCATION.

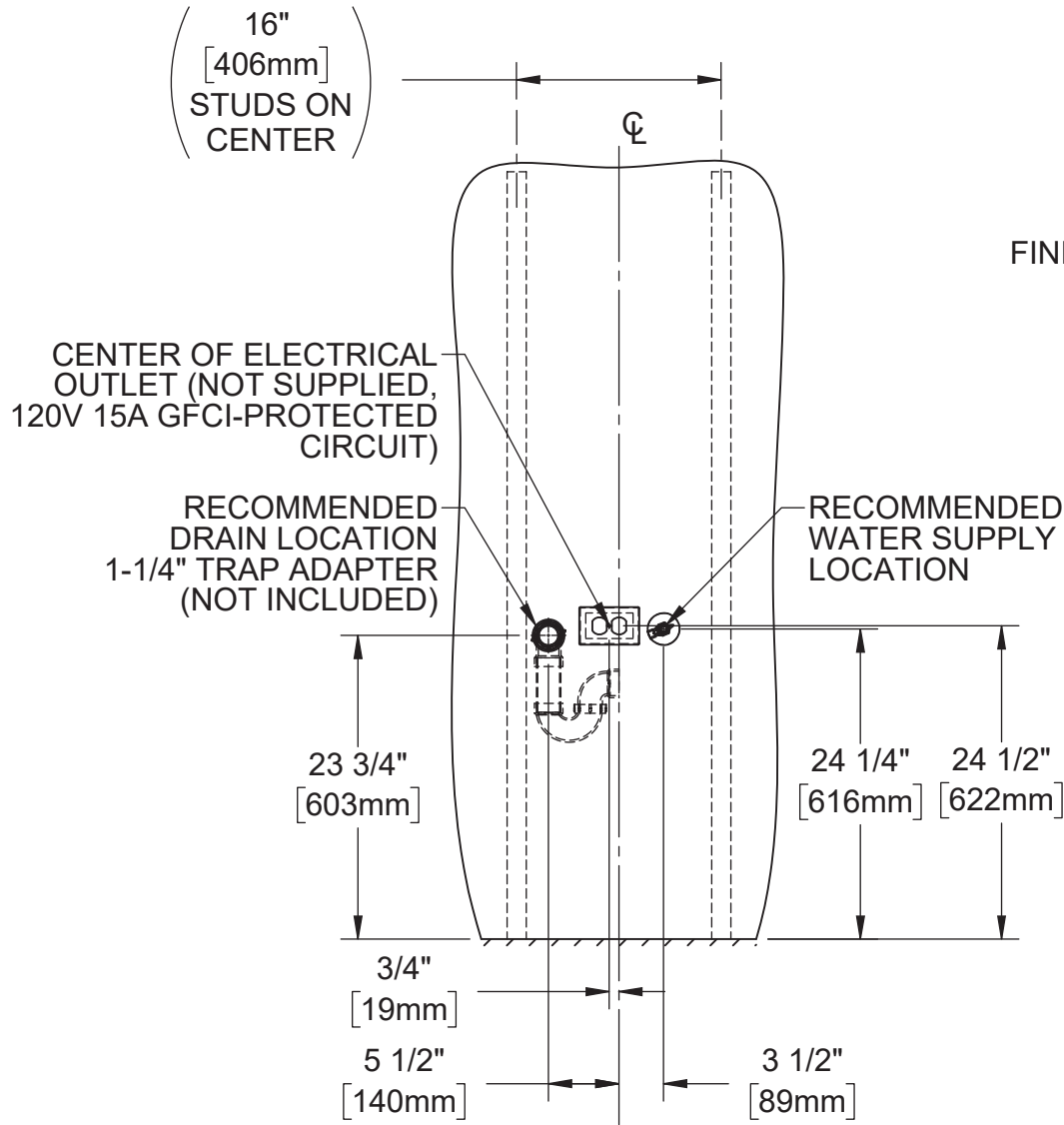

**TYPICAL WALL OPENING**

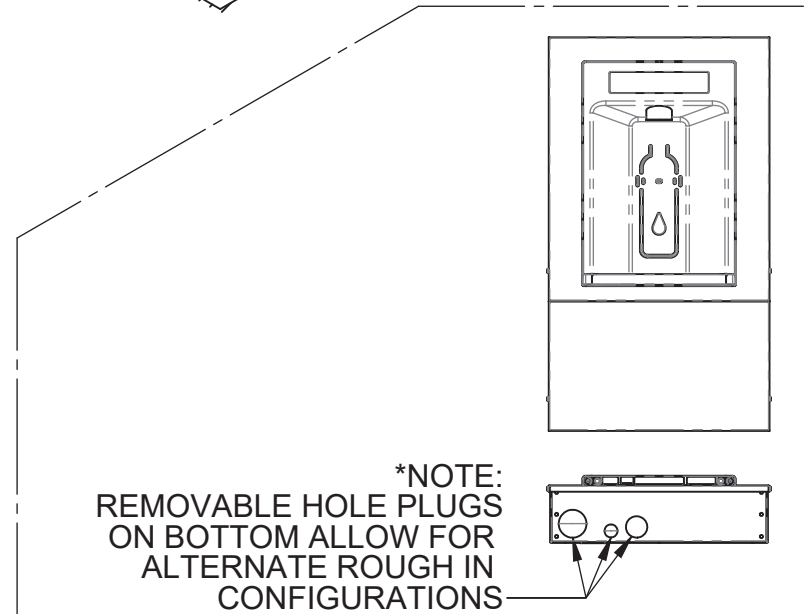
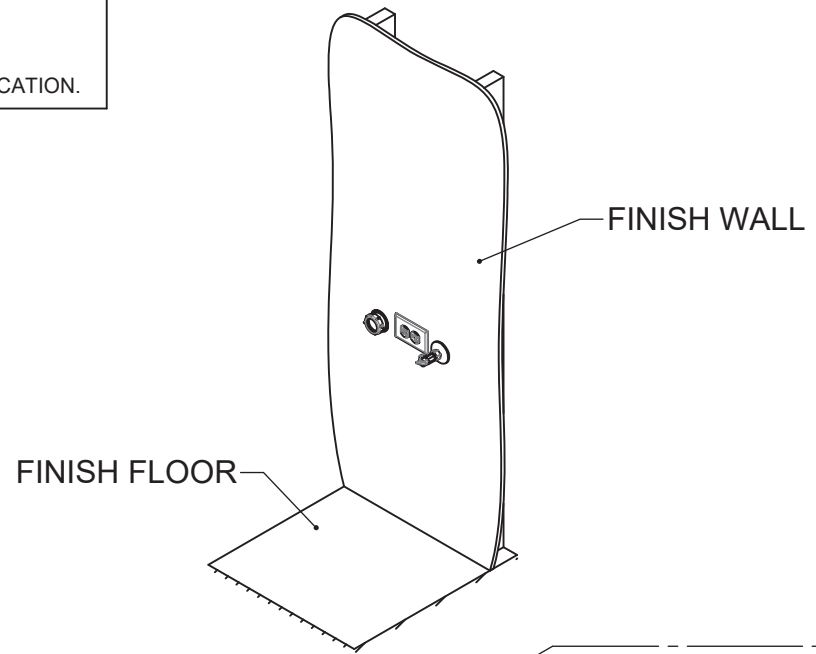

1455 KLEPPE LANE  
SPARKS, NEVADA 89431  
(775) 359-4712 FAX (775) 359-7424  
E-MAIL: HAWS@HAWS.CO.COM  
WEBSITE: WWW.HAWS.CO.COM

ECN: 6000	REV. ECN: 6000	BY: DHP	MODEL(S): 2000HSSM, BOTTLE FILLER	PART NUMBER: 0510002226.D
DRAWN: DHP	DATE: 08/16/23	CHKD:		REVISION: 1
APPROVED:	DATE:		SCALE: 1:20   DRAWING TYPE: INSTALLATION	SIZE: A   SHEET 2 OF 7

NOTES:

5. REMOVE LOWER PANEL BY REMOVING 2X #8-32 PANEL SCREWS (T20 TORX).
6. REMOVE WATER FILTER AND SET ASIDE.
7. REMOVE MOUNTING BRACKET FROM BOTTLE FILLER ASSEMBLY BY REMOVING #10-24 PANEL SCREW IN REAR OF UNIT.
8. INSTALL MOUNTING BRACKET LEVEL TO FLOOR AND CENTERED BETWEEN STUDS USING 4X 1/4" STRUCTURAL SCREWS (NOT SUPPLIED).

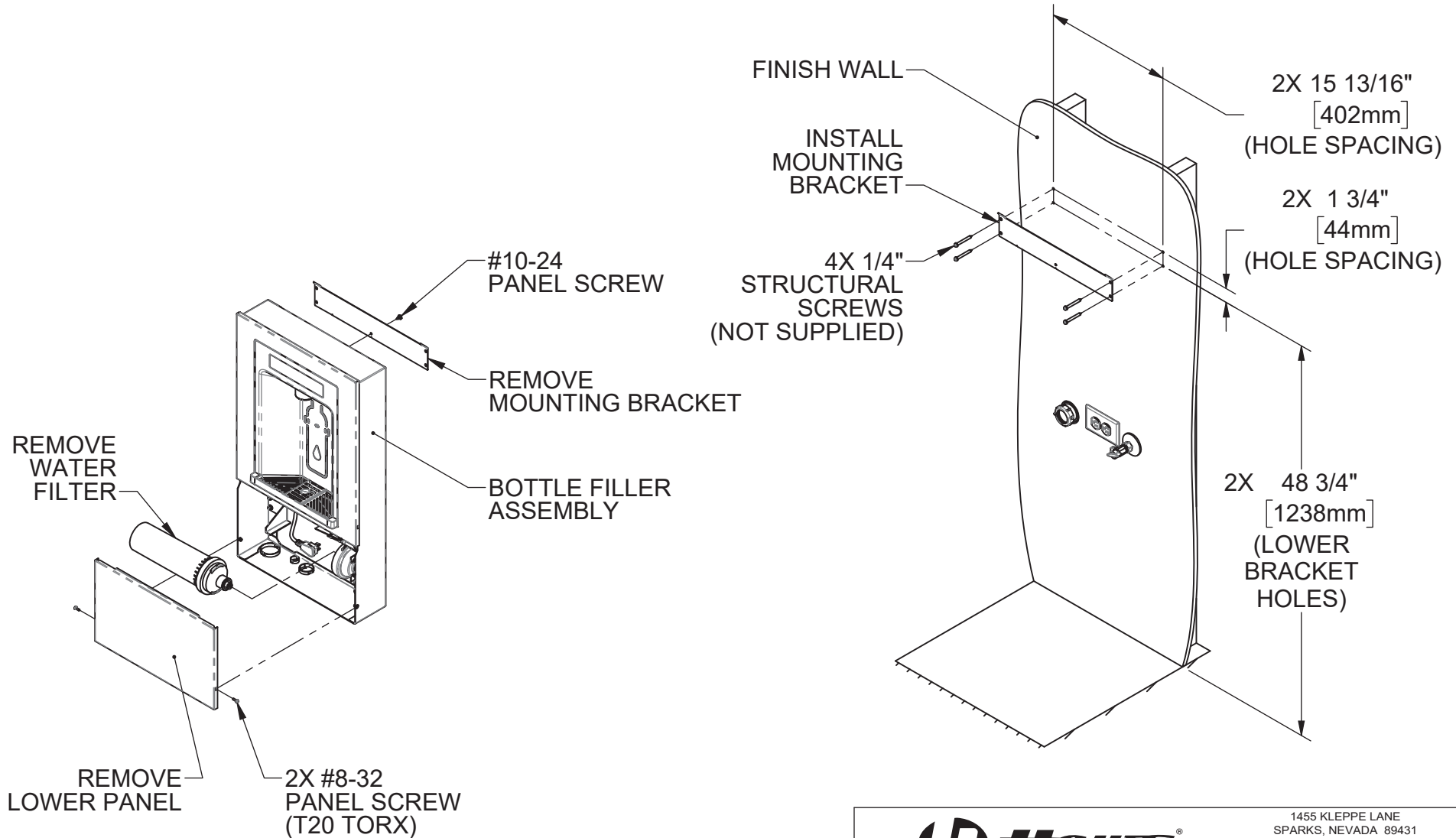

(DRAIN AND WATER SUPPLY COMPONENTS HIDDEN FOR CLARITY)

		1455 KLEPPE LANE SPARKS, NEVADA 89431 (775) 359-4712 FAX (775) 359-7424 E-MAIL: HAWS@HAWSO.COM WEBSITE: WWW.HAWSO.COM	
		ECN: 6000 REV. ECN: 6000 DRAWN: DHP APPROVED:	BY: DHP DATE: 08/16/23 DATE:
SCALE: 1:15		DRAWING TYPE: INSTALLATION	SIZE: A SHEET 3 OF 7

NOTES:

9. HANG BOTTLE FILLER ON MOUNTING BRACKET.
10. INSTALL 2X 1/4" STRUCTURAL SCREWS TO SECURE ENCLOSURE TO WALL.

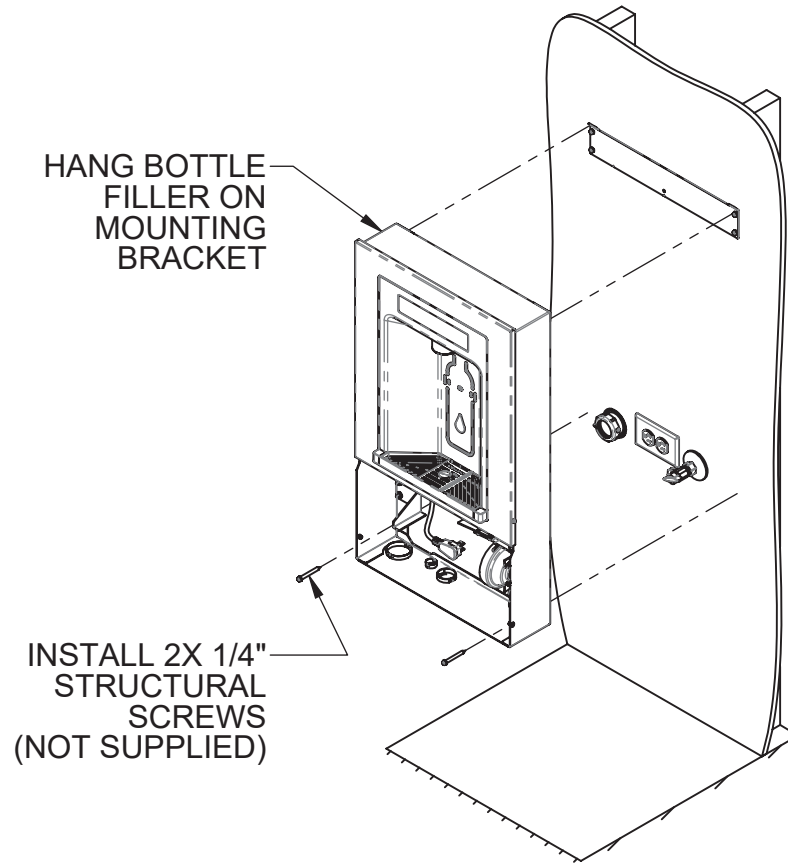

(DRAIN AND WATER SUPPLY COMPONENTS HIDDEN FOR CLARITY)

			1455 KLEPPE LANE SPARKS, NEVADA 89431 (775) 359-4712 FAX (775) 359-7424 E-MAIL: HAWS@HAWS.CO.COM WEBSITE: WWW.HAWS.CO.COM		
			ECN: 6000	REV. ECN: 6000	BY: DHP
DRAWN: DHP	DATE: 08/16/23	CHKD.:			REVISION 1
APPROVED:	DATE:	SCALE: 1:15   DRAWING TYPE: INSTALLATION		SIZE: A	SHEET 4 OF 7

NOTES:

11. ATTACH DRAIN HOSE TO DRAIN STACK USING SUPPLIED DRAIN HOSE ADAPTER AND HOSE CLAMP. ENSURE THAT DRAIN HOSE HAS A DOWNWARD SLOPE ALONG ITS FULL LENGTH.
12. ADHERE TO LOCAL, STATE, AND/OR FEDERAL CODES FOR PROPER DRAIN STACK AND TRAP INSTALLATION.

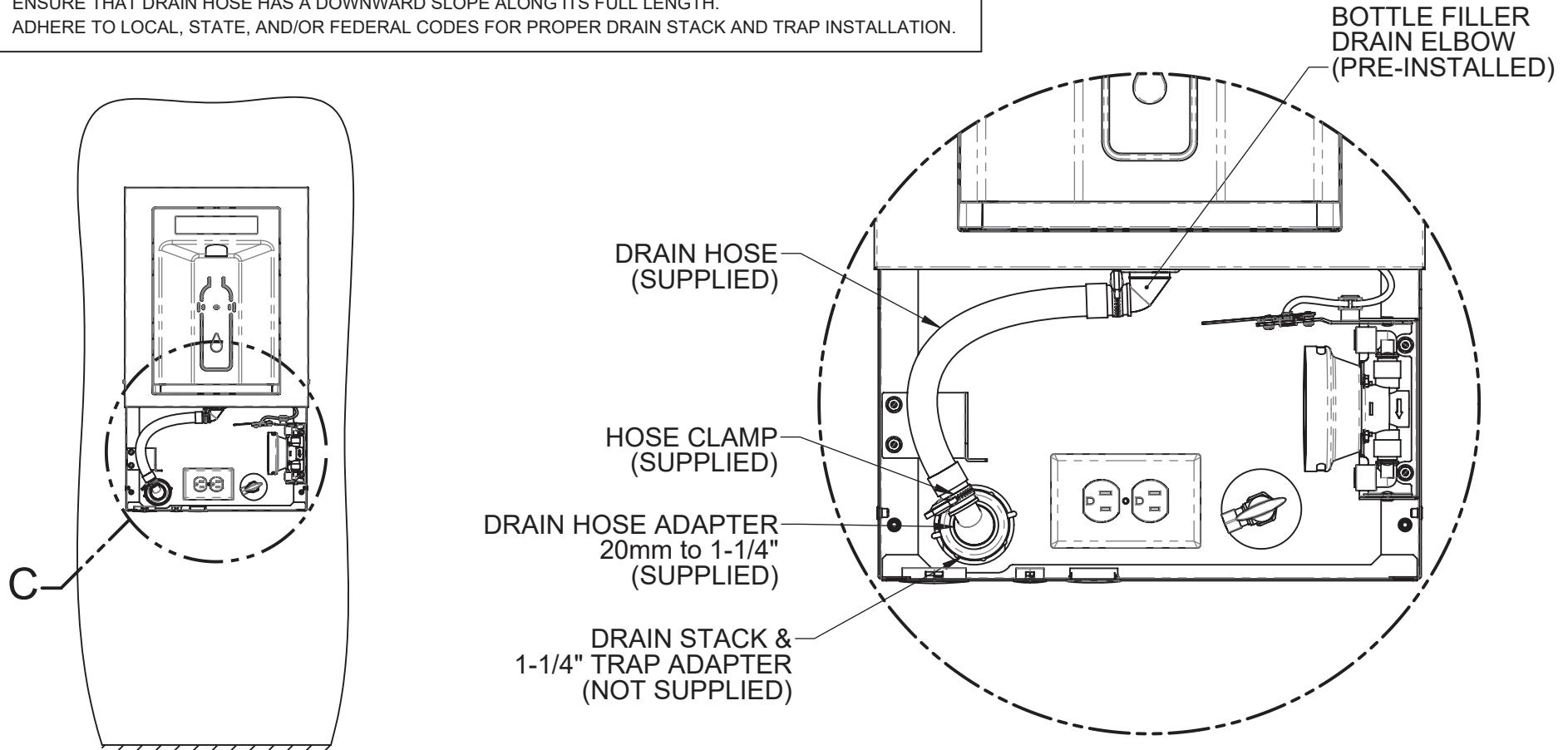

**DETAIL C**  
(ELECTRICAL AND WATER SUPPLY COMPONENTS HIDDEN FOR CLARITY)

**DRAIN HOSE ADAPTER INSTALLATION**

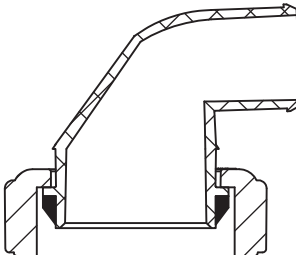

- 1-1/4" TRAP ADAPTER (NOT SUPPLIED)
- 1-1/4" SLIP JOINT WASHER (SUPPLIED)
- 1-1/4" NUT (SUPPLIED)

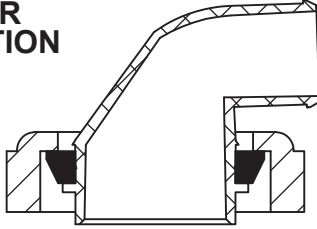

- 1-1/2" TRAP ADAPTER (NOT SUPPLIED)
- 1-1/2" X 1-1/4" SLIP JOINT WASHER (NOT SUPPLIED)
- 1-1/2" NUT (NOT SUPPLIED)



1455 KLEPPE LANE  
SPARKS, NEVADA 89431  
(775) 359-4712 FAX (775) 359-7424  
E-MAIL: HAWS@HAWS.CO.COM  
WEBSITE: WWW.HAWS.CO.COM

ECN: 6000	REV. ECN: 6000	BY: DHP	MODEL(S) 2000HSSM, BOTTLE FILLER	PART NUMBER 0510002226.D
DRAWN: DHP	DATE: 08/16/23	CHKD:		REVISION 1
APPROVED:	DATE:	SCALE: 1:15	DRAWING TYPE: INSTALLATION	SIZE: A SHEET 5 OF 7

NOTES:

12. INSTALL 3/8" TUBING AS SHOWN. NOTE DIRECTION OF FLOW ARROWS ON FILTER. CUT ALL TUBING SQUARE AND CLEAN AS REQUIRED. ENSURE TUBING IS FULLY INSERTED INTO PUSH-TO-CONNECT FITTINGS.
13. CONNECT THE WATER SUPPLY LINE TO THE WATER SUPPLY STOP USING COMPRESSION NUT (INCLUDED WITH YOUR SUPPLY STOP), FOLLOWED BY THE PLASTIC FERRULE (SUPPLIED), AND THE BRASS TUBE SUPPORT (SUPPLIED). INSERT SUPPLY LINE INTO THE SUPPLY STOP UNTIL IT BOTTOMS OUT. THREAD THE NUT ONTO THE SUPPLY STOP UNTIL FINGER TIGHT. PUT A LINE ON THE NUT USING A MARKER. TIGHTEN EXACTLY ONE ADDITIONAL FULL TURN (360 DEG) WITH A WRENCH, USING THE LINE TO COUNT TURNS. \*NOTE THE CORRECT ORIENTATION OF THE PLASTIC FERRULE. \*DO NOT USE THE BRASS FERRULE INCLUDED WITH YOUR SUPPLY VALVE.

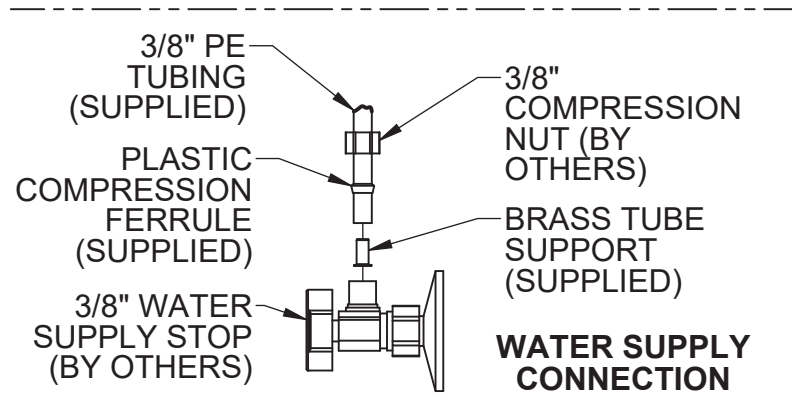
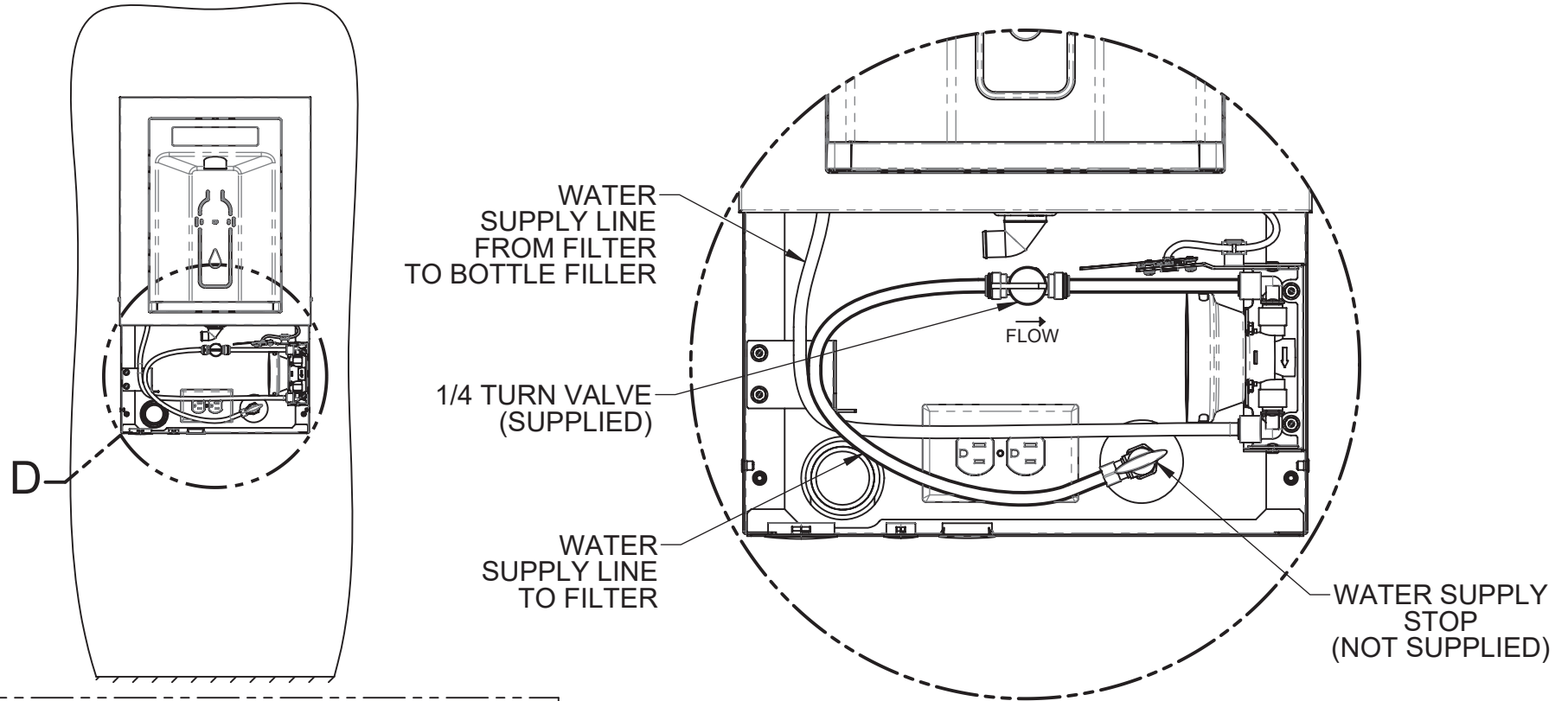

**DETAIL D**  
(DRAIN AND ELECTRICAL COMPONENTS HIDDEN FOR CLARITY)

		1455 KLEPPE LANE SPARKS, NEVADA 89431 (775) 359-4712 FAX (775) 359-7424 E-MAIL: HAWS@HAWS.CO.COM WEBSITE: WWW.HAWS.CO.COM	
		ECN: 6000 REV. ECN: 6000 DRAWN: DHP APPROVED:	BY: DHP DATE: 08/16/23 DATE:
SCALE: 1:15		DRAWING TYPE: INSTALLATION	SIZE: A SHEET 6 OF 7

NOTES:

- 14. INSTALL WATER FILTER AND TURN ON WATER SUPPLY.
- 15. CHECK ALL FITTINGS FOR LEAKS AND ENSURE DRAIN FITTINGS ARE TIGHT.
- 16. CONNECT BOTTLE FILLER POWER CORD PLUG TO WALL OUTLET.
- 17. INSTALL LOWER PANEL USING 2X #8-32 PANEL SCREWS (PREVIOUSLY REMOVED).
- 18. INSTALLATION COMPLETE.

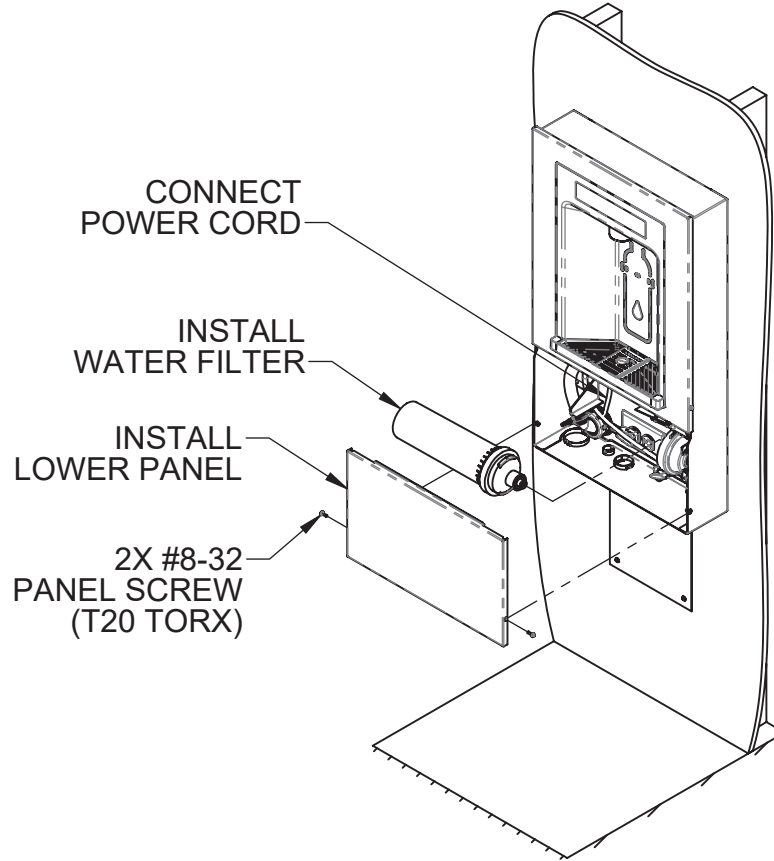

			1455 KLEPPE LANE SPARKS, NEVADA 89431 (775) 359-4712 FAX (775) 359-7424 E-MAIL: HAWS@HAWS.CO.COM WEBSITE: WWW.HAWS.CO.COM	
ECN: 6000	REV. ECN: 6000	BY: DHP	MODEL(S) 2000HSSM, BOTTLE FILLER	PART NUMBER 0510002226.D
DRAWN: DHP	DATE: 08/16/23	CHKD:		REVISION 1
APPROVED:	DATE:	SCALE: 1:15	DRAWING TYPE: INSTALLATION	SIZE: A SHEET 7 OF 7