

SPECIFICATIONS

Model 6477 retrofit filter kit is used with the Haws 3600 series outdoor pedestal fountains and includes the 6428 filter, filter bracket and supply line parts. It is a carbon block filter cartridge with a service life of 1 year/3000-gallons (11356 L). Tested and certified by CSA against NSF/ANSI Standard 42 for the reduction of chlorine (taste and odor) and against NSF/ANSI Standard 53 for the reduction of lead and cysts.

APPLICATIONS

This retrofit filter kit is designed specifically for the Haws outdoor models 3602, 3603, 3610, 3611 and 3612. (Not intended for freeze-resistant models)

PERFORMANCE DATA SHEET

IMPORTANT NOTICE: Read this Performance Data Sheet and compare the capabilities of this unit with your actual water treatment needs. It is recommended that, before purchasing a water treatment unit, you have your water supply tested to determine your actual water treatment needs.



Substance	Influent Challenge Concentration	Maximum Permissible Product Water Concentration mg/L or Reduction Requirement	Average Percent Reduction
Chlorine, Taste and Odor	2.0 mg/L \pm 10%	\geq 50%	>97.3%
Cyst Reduction	Minimum 50,000/L	99.95%	>99.99%
Lead 6.5 pH Reduction	0.15 mg/L \pm 10%	0.010 mg/L	>99.7%
Lead 8.5 pH Reduction	0.15 mg/L \pm 10%	0.010 mg/L	>99.7%

This filter has been tested according to NSF/ANSI 42/53 for the reduction of the substances listed. The concentration of the indicated substances in water entering the system was reduced to a concentration less than or equal to the permissible limit for water leaving the system, as specified in NSF/ANSI 42/53.

Testing was performed under standard laboratory conditions. The contaminants or other substances removed or reduced by this water treatment device are not necessarily in all users' water. Filter performance may vary based on local water conditions.

INSTALLATION INSTRUCTIONS FOR 3000 GALLON FILTER

STEP 1: USE 2X SLOT-HEAD 10-32 X 1/2 SCREWS (SUPPLIED) TO SECURE FILTER BRACKET TO THREADED HOLES ON MOUNTING BRACKET (SUPPLIED).

STEP 2: USE 4X PHILLIPS-HEAD #10 X 12mm THREAD-CUTTING SCREWS (SUPPLIED) TO SECURE FILTER HEAD TO FILTER BRACKET. ORIENT DIRECTION OF FLOW ARROW TOWARDS FRONT OF PEDESTAL.

STEP 3: INSERT 2X 3/8" PUSH-CONNECT ELBOW FITTINGS (SUPPLIED) INTO FILTER HEAD (SUPPLIED). INSERT FULLY.

STEP 4: USE 2X TAMPER-RESISTANT 1/4-20 X 5/16 SCREWS (SUPPLIED) TO SECURE MOUNTING BRACKET SUB-ASSEMBLY (STEPS 1 - 3) TO PEDESTAL. USE THREADED HOLES SHOWN.

REFERENCE COMPLETE 6477 FILTER BRACKET MOUNTING ASSEMBLY (SHOWN ON SHEET 2) FOR FINISHED INSTALLATION AS RETROFITTED ON AN EXISTING CUSTOMER UNIT OR A NEW INSTALLATION.

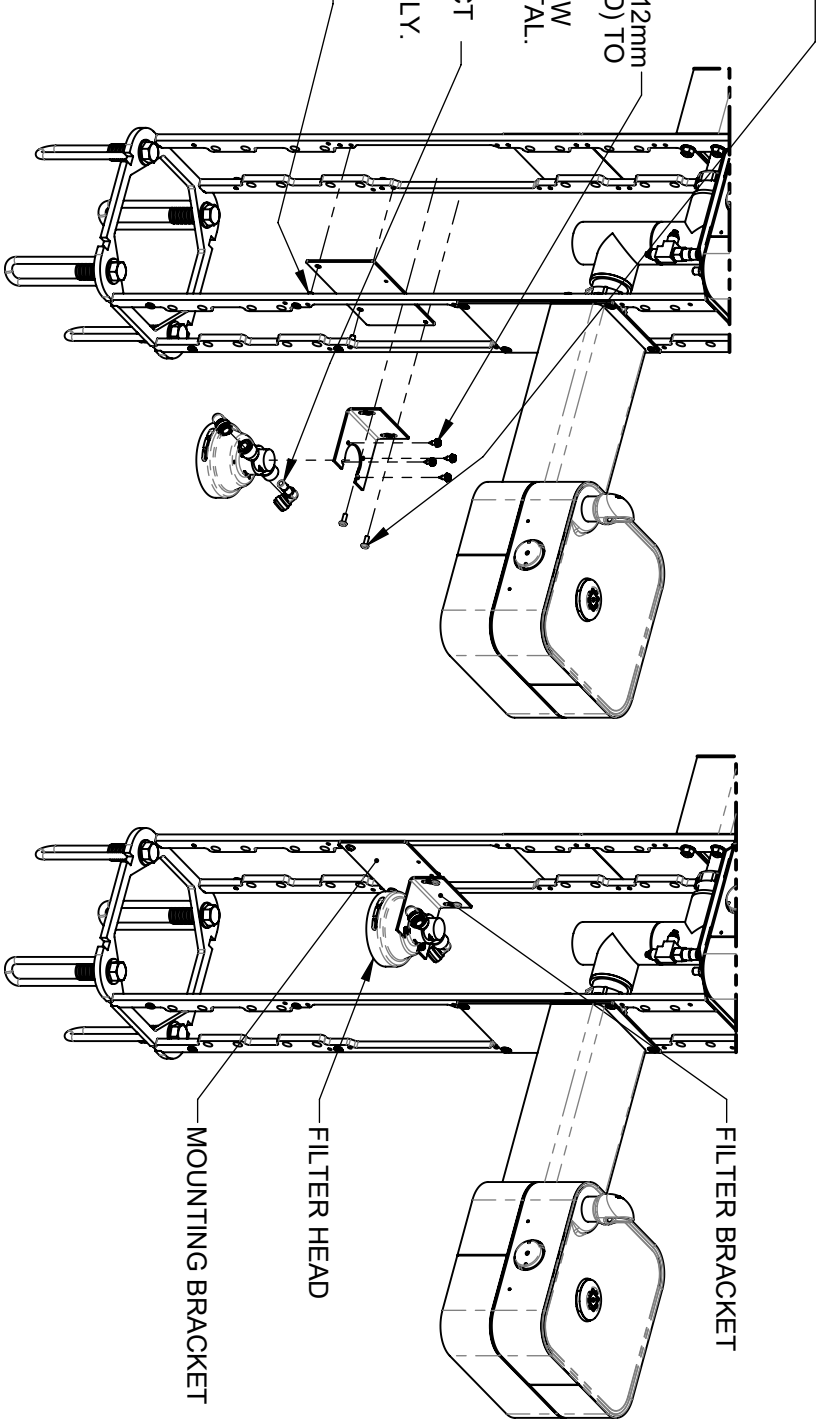

6477 FILTER BRACKET MOUNTING INSTRUCTIONS
(PEDESTAL SIDES, DRAIN HIDDEN FOR CLARITY)

6477 FILTER HEAD/BRACKET MOUNTING (ASSEMBLED)
(PEDESTAL SIDES, DRAIN HIDDEN FOR CLARITY)

NOTES:

- FOR NEW INSTALLATIONS USING BASE MODEL "F" SERIES UNITS (3612F SHOWN FOR REF. ONLY) - 6477 FILTER AND MOUNTING HARDWARE CAN BE INSTALLED BEFORE OR AFTER DRAIN INSTALLATION.
- FOR RETROFIT INSTALLATIONS ON EXISTING UNITS (MODELS 3602, 3610, 3611 OR 3612) - 6477 FILTER AND MOUNTING HARDWARE CAN BE INSTALLED WITHOUT CHANGING EXISTING DRAIN PIPE. SEE SHEET 2 FOR DETAILS.

3. THIS FILTER KIT (3000-GALLON CAPACITY) IS TO BE USED ON NEW INSTALLATIONS WITH MODELS 3602F, 3610F, 3611F AND 3612F, AS WELL AS FOR RETROFITTING EXISTING MODELS 3602, 3610, 3611 AND 3612. **NOTE: SEE SHEET 3 FOR OPTIONAL OWNER-PROVIDED FILTER INSTALLATION INSTRUCTIONS.**

		1455 KLEPPE LANE SPARKS, NEVADA, 89431	
Since 1906		(775) 359-4712 FAX (775) 359-7424	
		E-MAIL: HAWS@HAWSCO.COM	
		WEBSITE: WWW.HAWSCO.COM	
ENR: 5718	REV: E090	BY: F.V.	MODEL(S): 6477
DRAWN: 18/05/24	DATE: 09/05/24	CHKD: J.S.	
APP'D: RH	DATE: 09/27/24	SCALE: 1:10	DRAWING TYPE: INSTALLATION
			SIZE: A
			SHEET 1 OF 3
		PART NUMBER: 0510002018.D	REVISION: 4

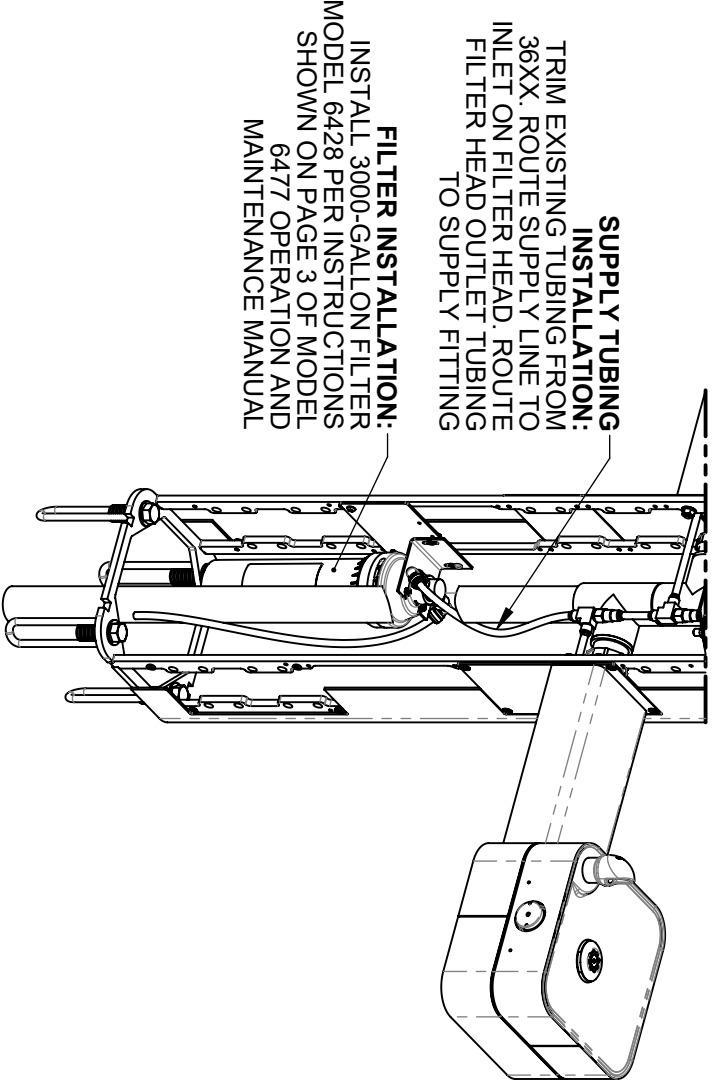

SUPPLY TUBING INSTALLATION:
 TRIM EXISTING TUBING FROM 36XX. ROUTE SUPPLY LINE TO INLET ON FILTER HEAD. ROUTE FILTER HEAD OUTLET TUBING TO SUPPLY FITTING

FILTER INSTALLATION:
 INSTALL 3000-GALLON FILTER MODEL 6428 PER INSTRUCTIONS SHOWN ON PAGE 3 OF MODEL 6477 OPERATION AND MAINTENANCE MANUAL

6477 FILTER AND SUPPLY LINE INSTRUCTIONS
 PEDESTAL SIDES HIDDEN FOR CLARITY

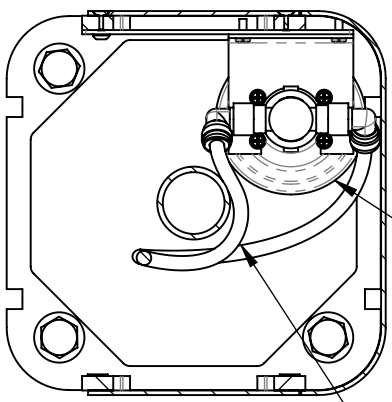

6477 FILTER ASSEMBLY (3000-GALLON CAPACITY) CAN BE INSTALLED WITH DRAIN IN PLACE

ROUTE SUPPLY TUBING AROUND DRAIN AS NEEDED.

6477 FILTER AND SUPPLY LINE
 INTERNAL TOP-DOWN PEDESTAL VIEW
 SCALE 1:8

6477 FILTER MOUNTING KIT SHOWN ON MODEL 3612/3612F FOR REFERENCE (ONLY). INSTALLATION INSTRUCTIONS APPLY TO EITHER NEW OR RETROFIT APPLICATIONS USING THE SUPPLIED 3000-GALLON CAPACITY FILTER SHOWN (THE SUPPLIED 1-1/2" X 3" PVC PIPE AND 45° PVC ELBOWS (QTY. 2) ARE NOT REQUIRED FOR THIS SPECIFIC APPLICATION).
NOTE: SEE SHEET 3 FOR OPTIONAL OWNER-PROVIDED FILTER INSTALLATION INSTRUCTIONS.

		1455 KLEPPE LANE SPARKS, NEVADA 89431 (775) 359-4712 FAX (775) 359-7424 E-MAIL: HAWS@HAWSCCO.COM WEBSITE: WWW.HAWSCCO.COM	
ENCL	REV/ENCL	BY:	MODEL(S)
5718	6080	F.V.	6477
DRAWN	DATE	CHK'D	
APP'D	DATE	DATE	
RH	06/27/24	SCALE	1:10
		DRAWING TYPE	INSTALLATION
		SIZE	A
		SHEET	2 OF 3
		PART NUMBER	0510002018.D
		REVISION	4

OPTIONAL OWNER-PROVIDED FILTER INSTALLATION

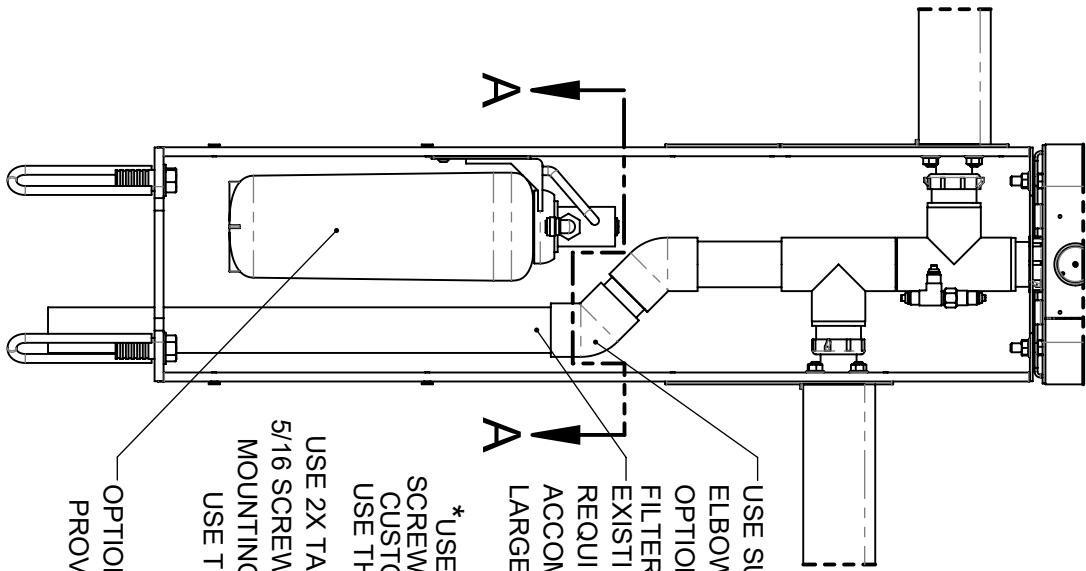

USE SUPPLIED 3" PVC PIPE AND ELBOWS TO ROUTE DRAIN AROUND OPTIONAL CUSTOMER-PROVIDED FILTER.
 EXISTING DRAIN PIPE. DRAIN MAY REQUIRE OFFSET LOCATION TO ACCOMMODATE FILTER WITH A LARGER DIAMETER.

*USE 2X SLOTTED 10-32 X 1/2" SCREWS (SUPPLIED) TO MOUNT CUSTOMER-PROVIDED FILTER. USE THREADED HOLES SHOWN

USE 2X TAMPER-RESISTANT 1/4-20 X 5/16 SCREWS (SUPPLIED) TO SECURE MOUNTING BRACKET TO PEDESTAL. USE THREADED HOLES SHOWN.

OPTIONAL OWNER-PROVIDED FILTER

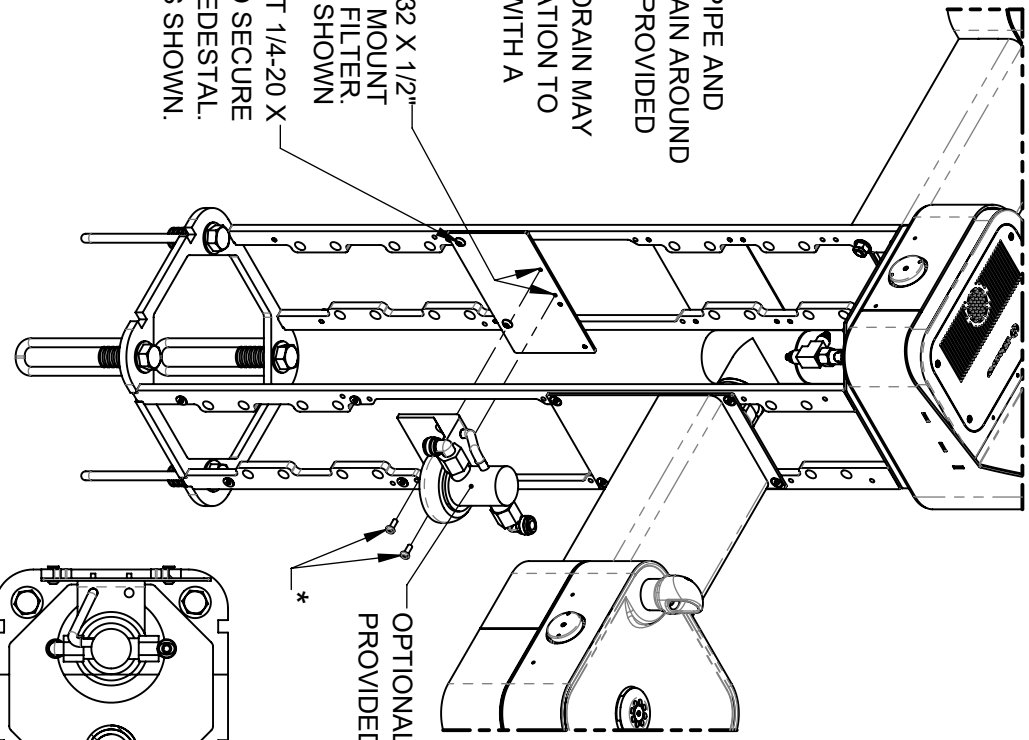

OPTIONAL OWNER-PROVIDED FILTER HEAD

DRAIN OFFSET 2" TO ACCOMMODATE LARGER FILTER MAY BE REQUIRED. CHECK FOR FILTER CLEARANCES BASED ON THE OPTIONAL FILTER YOU PROVIDE, PRIOR TO SETTING DRAIN & ANCHORS.

ALTERNATE DRAIN LOCATION FOR CUSTOMER SUPPLIED OPTIONAL FILTER SECTION A-A

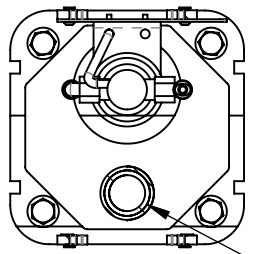

INSTRUCTIONS FOR OPTIONAL OWNER-PROVIDED FILTER.
 NOTE: MOUNTING BRACKET, 1-1/2" X 3" PVC PIPE AND 45° PVC ELBOWS (QTY. 2) SUPPLIED WITH 6477 FILTER MOUNTING KIT ARE REQUIRED (SHOWN ON MODEL 3612/3612F FOR REFERENCE ONLY).
 INSTALLATION INSTRUCTIONS APPLY TO EITHER NEW OR RETROFIT APPLICATIONS. SEE SHEETS 1 AND 2 FOR STANDARD FILTER (3000-GALLON CAPACITY) INSTALLATION INSTRUCTIONS.

		1455 KLEPPE LANE SPARKS, NEVADA, 89431	
Since 1906		(775) 359-4712 FAX (775) 359-7424	
		E-MAIL: HAWS@HAWS.CO.COM	
		WEBSITE: WWW.HAWS.CO.COM	
ENR: 5718	REV. ECR: B.V.	MODEL(S):	
DRAWN: J.M.	DATE: 06/09		
CHECKED: J.M.	DATE: 08/25/10		
APP'D: J.M.	DATE: 06/27/12	SCALE: 1/2"	DRAWING TYPE: INSTALLATION
RH:		SIZE: A	SHEET 3 OF 3
PART NUMBER: 6477		REVISION: 4	
0510002018.D			