

FEATURES & BENEFITS

CONSTRUCTION

Rugged ADA accessible 18 gauge Type 304 Stainless Steel swirl design bowls, 14 gauge Type 304 Stainless Steel brackets and bottle filler, and vandal-resistant bottom plates provides a long lasting unit with added peace of mind.

FRESH FILTERED WATER

Always fresh filtered water, 3000-gallon (11,356 L) capacity, reduces chlorine (taste and odor) and lead, and removes 99.99% of cysts, and comes with a mounting bracket.

BOTTLE FILLER

Vandal-resistant, 14-gauge Type 304 stainless steel bottle filler housing with push button operation and 1 gpm (3.78 L) laminar flow.

VANDAL RESISTANT

The bubbler heads, push buttons, round bowls, drain strainers and bottom plates are locked in place, discouraging unwanted vandal tampering.

BUBBLER HEADS

Polished chrome-plated brass bubbler heads with integral laminar flow prevents splashing while providing a superior flow pattern. The integral 11/16" dia. basin shank and stainless anti-rotational roll pin add vandal resistant strength. Shielded, angled stream opening provides a steady source of drinking water at .45 gpm.

FOUNTAIN VALVES

The push-button activated valves have all stainless steel bodies, with chrome plated brass push button assemblies which allow for front access to water stream adjustment, water control cartridge, and water supply strainer replacement without having to go through the bottom plate. Operating pressure range of 30 to 90 psi (2.1 to 6.2 bar).

MOUNTING

Heavy-duty 16-gauge galvanized steel mounting frame with welded-in heavy-duty 10 gauge mounting plate with pre-punched mounting holes. Further convenience is given to the chiller with the integral fold-out shelf, and an in-wall 3/16" thick steel mounting plate for the bottle filler.

OPTIONS

- Copper Push Button: Model PBA6C, flanged push button assembly with antimicrobial copper button
- Fountain Skirt: Model SK3, stainless steel cane touch skirt for installation on high unit in some applications that may need to comply with ADA protruding objects guidelines.

For more information, visit www.hawsco.com or call (888) 640-4297.



SPECIFICATIONS

Model 1011.8PF ADA vandal-resistant wall-mounted filtered drinking fountain and bottle filler shall include dual 18-gauge Type 304 Stainless Steel satin finish basins with integral swirl design, 14 gauge Type 304 Stainless Steel wall brackets and bottle filler bracket, 3000 gallon carbon block filter reduces chlorine (taste and odor) and lead, and removes 99.99% of cysts with mounting bracket, 100% lead-free waterways, vandal-resistant push-button operated stainless steel valves with front accessible cartridge and flow adjustment, polished chrome-plated brass vandal resistant bubbler heads with integral laminar anti-squirt flow, 1 gpm (3.78 L) laminar flow bottle filler with in-wall 3/16" thick steel mounting plate, chrome-plated brass vandal-resistant waste strainers, vandal-resistant bottom plates, stainless steel satin finish back panels and louvered intrusion-proof grill, high and low fountain mounting levels, and 1-1/4" O.D. (3.2 cm) waste pipes. The refrigeration system is hermetically sealed and delivers a minimum of 8 gph (30.3 L) of water at 50° F (10° C), 115 Volts, 60Hz, rated watts: 370, full load amps: 5. Haws electric water coolers comply with ARI Standard 1010 and ANSI A117.1, and are listed by Underwriter Laboratories to U.S. and Canadian standards.

APPLICATIONS

Perfect for either public or private indoor/outdoor settings, Model 1011.8PF is great in areas where aesthetics are important to the overall appeal of the architecture. This series is precisely mounted, making it a nice addition to any surrounding. Beautiful satin finish helps to maintain the fountains overall appeal, so it always remains looking as new as it did when it was installed. Specifically, this type of wall mounted drinking fountain may be placed in settings such as: schools and other locations in and around office buildings where the temperature remains above freezing. Model meets all current Federal Regulations for the disabled including those in the Americans with Disabilities Act. Haws manufactures drinking fountains, faucets and electric water coolers to be lead-free by all known definitions including NSF/ANSI/CAN 61- Section 9, NSF/ANSI/CAN 372, California Proposition 65, and the Federal Safe Drinking Water Act. Product is compliant to California Health and Safety Code 116875 (AB 1953-2006), and 116876 (AB 100) "NSF/ANSI/CAN 61: Q ≤ 1".



NOTE: FOR FILTERED WATER, OTHERS TO SUPPLY FILTER PRIOR TO THIS CONNECTION AND MOUNT TO SIDE OF MOUNTING FRAME IN THIS LOCATION.

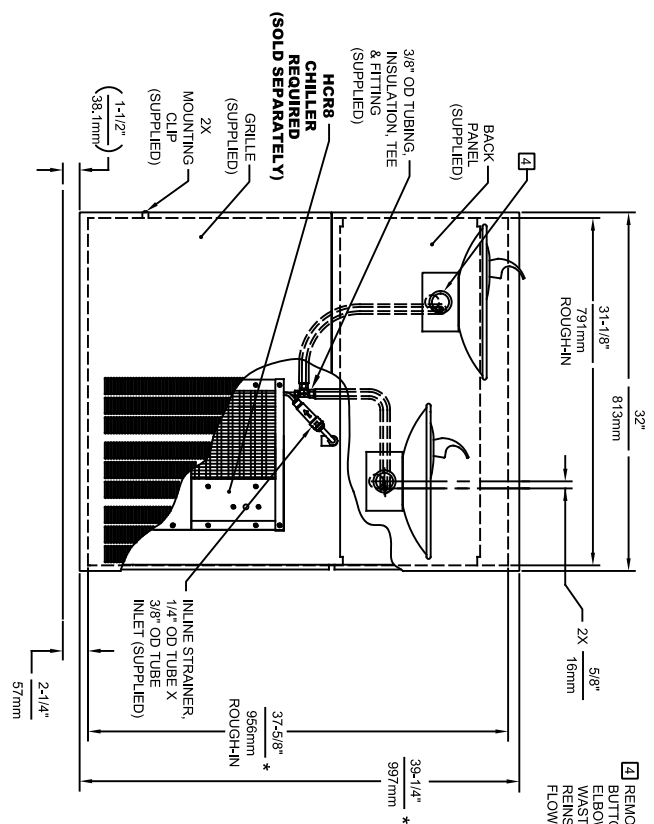
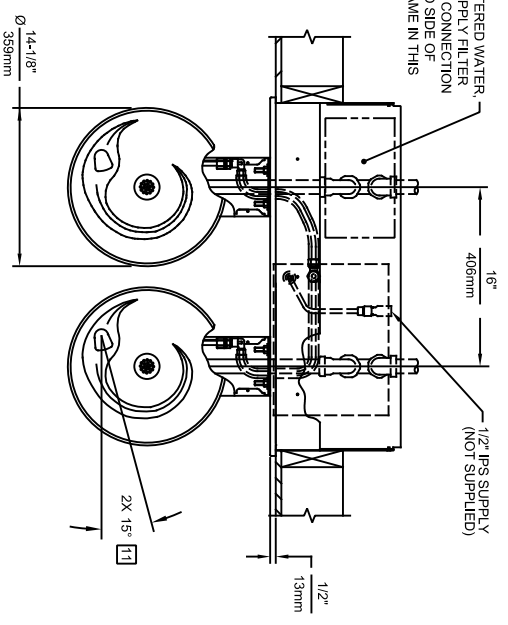

4 REMOVE VALVE FROM PUSH BUTTON TO INSTALL WASTE ELBOW ONTO BOWL. AFTER WASTE ELBOW IS INSTALLED, REINSTALL VALVE & ADJUST FLOW

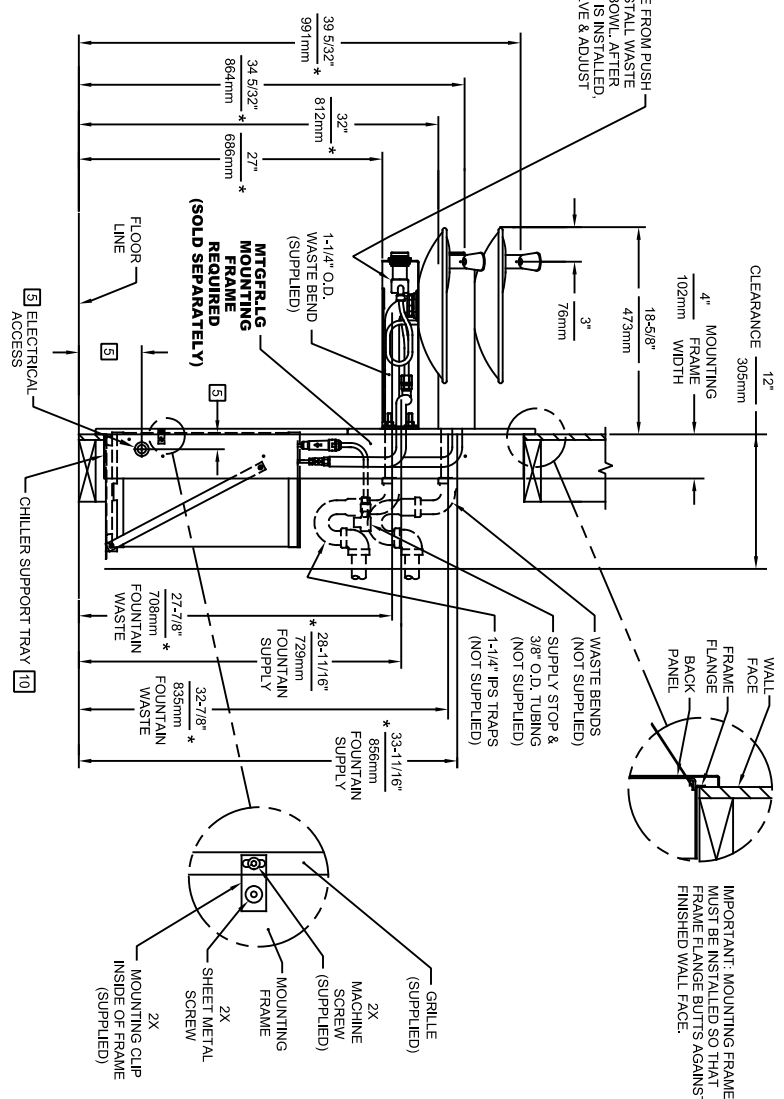

- NOTES:**
- HOLD ROUGH-IN DIMENSIONS 1/16" (3.2mm).
 - WHEN INSTALLING THIS UNIT, LOCAL, STATE, OR FEDERAL CODES SHOULD BE ADHERED TO. FOR DIMENSIONS (LOCATIONS), WASTE AND SUPPLY REQUIREMENTS OTHER THAN SHOWN, DIMENSIONS MARKED (*) MUST BE ADJUSTED ACCORDINGLY.
 - INSTALLER MUST PROVIDE TRAP FOR PROPER INSTALLATION.
 - REFER TO 5874 SERIES OPERATION AND MAINTENANCE MANUAL FOR PUSH BUTTON AND VALVE INSTALLATION/MAINTENANCE INSTRUCTIONS.
 - REFER TO MTFGR/LG INSTALLATION DRAWING FOR ROUGH-IN DIMENSIONS.
 - INSERT 5/16"-18 PANEL INSERTS FROM OPPOSITE SIDE AT LOCATIONS SHOWN BY DARKENED HOLES. HOLE COMBINATIONS SHOWN ARE FOR USE WITH LOW FOUNTAIN ON THE RIGHT AND THE HI FOUNTAIN ON THE LEFT. USE OPPOSITE HOLES FOR HI ON RIGHT AND LOW ON LEFT.
 - HOLE COMBINATION SHOWN BELOW IS FOR USE WITH LOW FOUNTAIN ON THE RIGHT AND HIGH FOUNTAIN ON THE LEFT. USE OPPOSITE HOLES FOR HIGH ON RIGHT AND LOW ON LEFT.
 - TO CHANGE FOUNTAIN MOUNTING, FIRST REMOVE SCREWS AND THEN SQUEEZE CLIPS ON NUT RETAINER TO POP OUT. SNAP INTO NEW POSITIONS AND REASSEMBLE SCREWS.
 - IMPORTANT: A L.H. LOW (OPTIONAL) CONVERGATION WILL REQUIRE A DIFFERENT BACK PANEL AND THE WASTE AND SUPPLY DIMENSIONS SHOWN (*) MUST BE REVERSED.
 - ALIGN HOLES IN CHILLER SUPPORT TRAY WITH HOLES IN FRAME AND FASTEN WITH #10 SHEET METAL SCREWS.
 - MAXIMUM ADJUSTABLE RANGE IS 15" FROM PARALLEL TO BACK WALL.

IMPORTANT: MOUNTING FRAME MUST BE INSTALLED SO THAT FRAME FLANGE BUTTS AGAINST FINISHED WALL FACE.

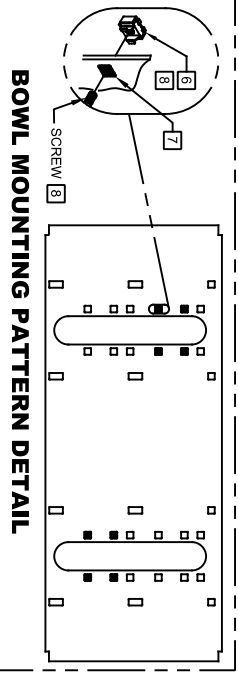

BOWL MOUNTING PATTERN DETAIL



Haws
Since 1906

1459 KLEPPE LANE
SPARKS, NEVADA 89431
(775) 359-4712 FAX (775) 359-7424
E-MAIL: HAWS@HAWS.CO.COM
WEBSITE: WWW.HAWS.CO.COM

ECN NO. REVISED PER BY: MODEL(S)
DRAWN: ENK, 6/125 FV H1011.8/H1011.8HPS
DATE: 07/97 CHKD. J.C.
RTM APPROVED: FV DATE: 10/22/24 SCALE: 1/18 DRAWING TYPE: INSTALLATION SIZE: A SHEET 1 OF 1

PART NUMBER: 0002080249.D
REVISION: 25

CALLOUT LEGEND	
A	1/4" OD WATER OUTLET
B	3/8" OD WATER INLET
C	TEMPERATURE CONTROL
D	JUNCTION BOX
E	ELECTRICAL WIRING OPENING

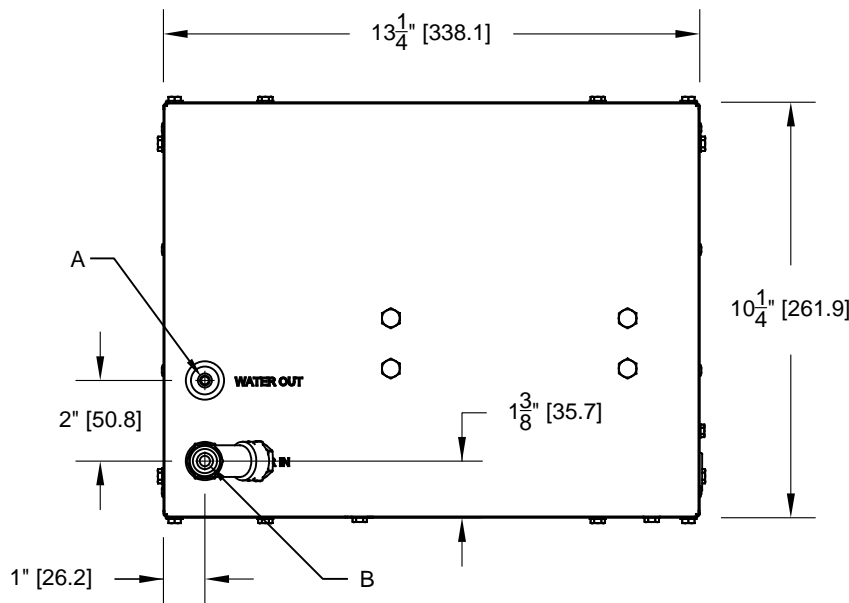

FIG. 2

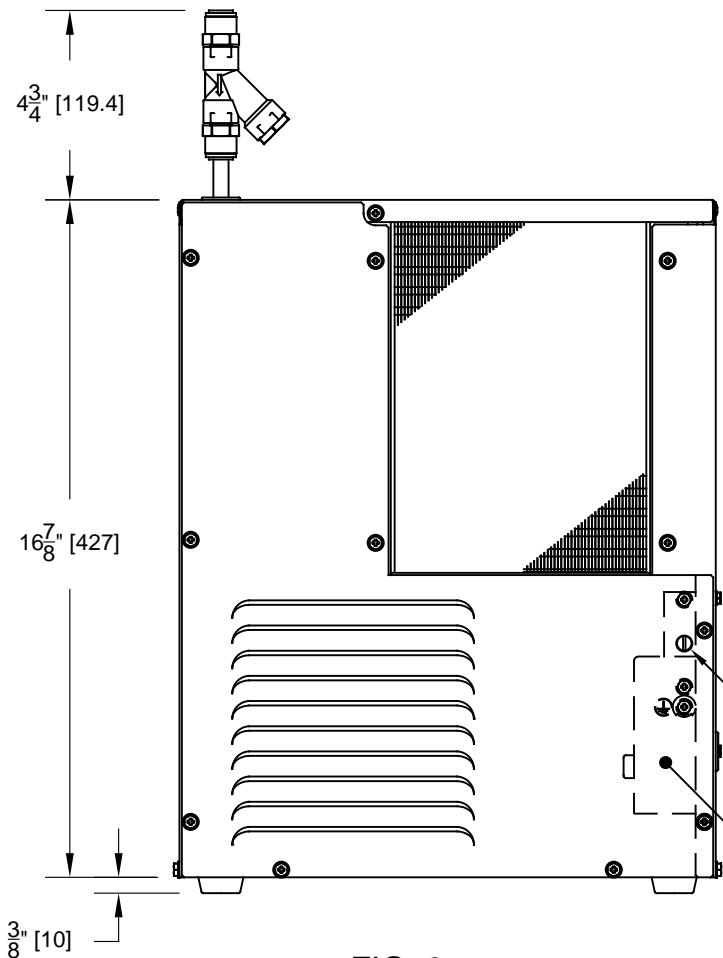

FIG. 3

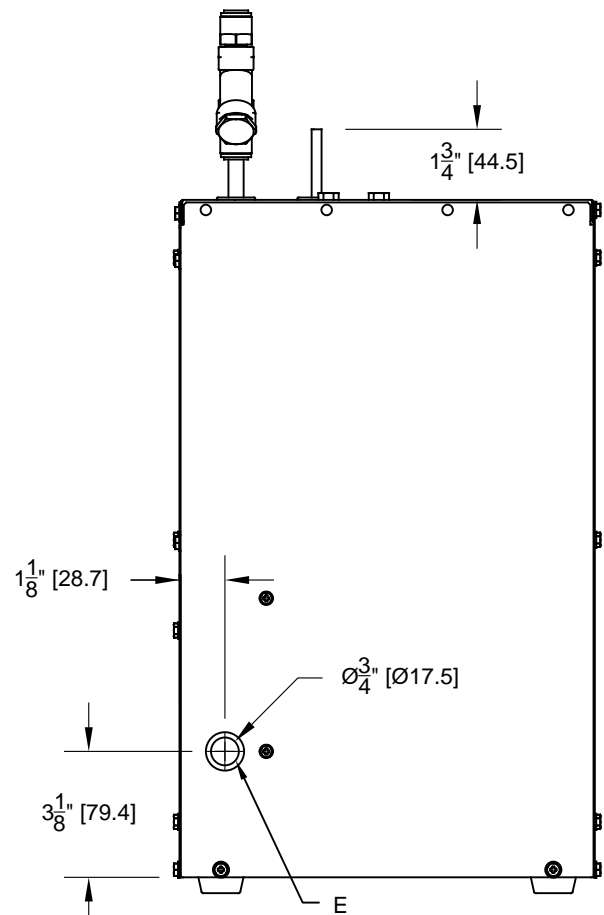

FIG. 4

		Haws [®]		1455 KLEPPE LANE SPARKS, NEVADA 89431 (775) 359-4712 FAX (775) 359-7424 E-MAIL: HAWS@HAWSCO.COM WEBSITE: WWW.HAWSCO.COM	
				ECN NO. 4997 DRAWN VWC APPROVED JL	REVISED PER BY ECN: 5401 DATE 01/25/16 DATE 02/05/19
SCALE: NA		DRAWING TYPE: INSTALLATION		SIZE: A	

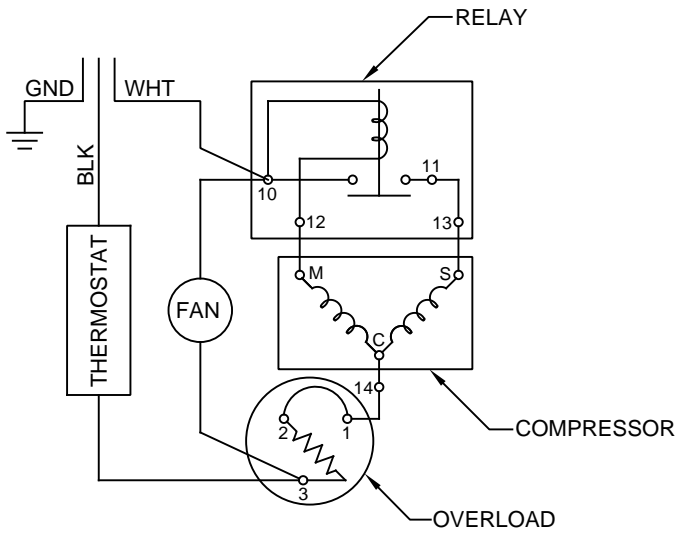

FIG. 5
WIRING DIAGRAM

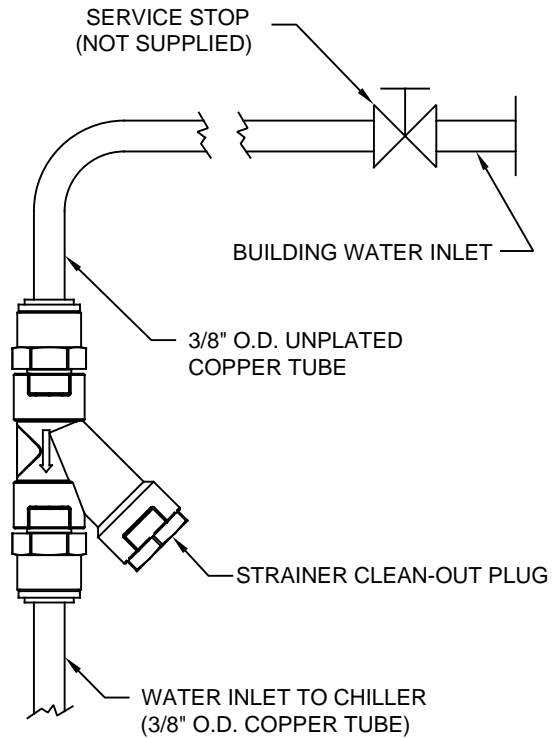
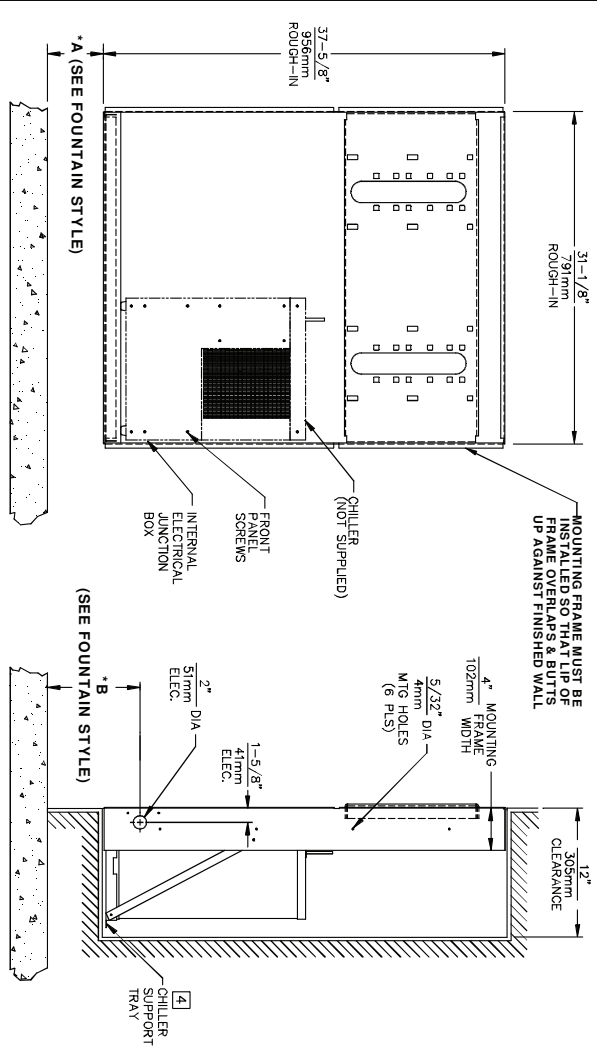

FIG. 6
WATER CONNECTION DIAGRAM

		Haws [®]		1455 KLEPPE LANE SPARKS, NEVADA 89431 (775) 359-4712 FAX (775) 359-7424 E-MAIL: HAWS@HAWS.CO.COM WEBSITE: WWW.HAWS.CO.COM	
				ECN NO. 4997 DRAWN VWC APPROVED JL	REVISED PER ECN: 5401 DATE 01/25/16 DATE 02/05/19
SCALE: NA		DRAWING TYPE: INSTALLATION		SIZE: A SHEET 2 OF 2	

THIS DOCUMENT IS TRUE AND CORRECT AT TIME OF PUBLICATION. CONTINUED PRODUCT IMPROVEMENTS MAKE SPECIFICATIONS AND MEASUREMENTS SUBJECT TO CHANGE WITHOUT NOTICE.



- CHILLER ELECTRICAL INSTALLATION**
1. ENSURE ELECTRICAL POWER IS OFF AND POWER MATCHES VOLTAGE, PHASE AND CYCLE LISTED ON CHILLER LABEL.
 2. REMOVE FRONT PANEL TO GAIN ACCESS TO INTERNAL JUNCTION BOX.
 3. HARDWIRE CHILLER THROUGH ITS SIDE, WIRE IN ACCORDANCE WITH LOCAL, STATE OR FEDERAL CODES.
 4. REPLACE FRONT PANEL. DO NOT APPLY POWER UNTIL WATER SUPPLY IS CONNECTED AND ON.

MOUNTING FRAME INSTALLATION

1. THIS FRAME IS USED WITH SEVERAL DIFFERENT MODELS. SEE INSTALLATION INSTRUCTIONS RECEIVED WITH THE FOUNTAIN FOR PROPER LOCATIONS OF 5/16"-18 PANEL NUT RETAINERS. FOR ROUGH-IN USE THE APPROPRIATE DIMENSIONS SHOWN ABOVE. WASTE AND SUPPLY HEIGHTS ARE ALSO DETAILED ON THE FOUNTAIN INSTALLATION INSTRUCTIONS.
2. HOLD ROUGH-IN DIMENSIONS ±1/8" (3.2mm).
3. WHEN INSTALLING THIS UNIT LOCAL, STATE OR FEDERAL CODES SHOULD BE ADHERED TO. FOR DIFFERENT INSTALLATION HEIGHTS, OTHER THAN SHOWN, DIMENSIONS MARKED (*) MUST BE ADJUSTED ACCORDINGLY.
4. ALIGN HOLES IN CHILLER SUPPORT TRAY WITH HOLES IN FRAME AND FASTEN IN PLACE WITH #10 SHEET-METAL SCREWS SUPPLIED WITH UNIT.
5. FOUNTAIN REMOVAL: FIRST REMOVE SCREWS AND THEN SQUEEZE CLIPS ON NUT RETAINER TO POP OUT. INSTALL IS REVERSE OF REMOVAL.
6. HOLE COMBINATION SHOWN ABOVE IS FOR USE WITH LOW FOUNTAIN ON THE RIGHT AND HIGH FOUNTAIN ON THE LEFT. USE OPPOSITE HOLES FOR HIGH ON RIGHT AND LOW ON LEFT.
7. IMPORTANT: A L.H. LOW (OPTIONAL) CONFIGURATION WILL REQUIRE A DIFFERENT BACK PANEL AND THE WASTE AND SUPPLY DIMENSIONS SHOWN (*) MUST BE REVERSED.

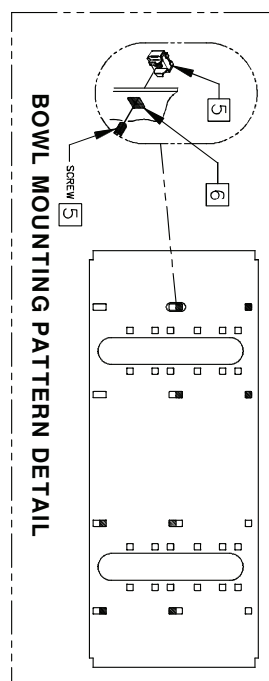

* IF YOUR FOUNTAIN IS THIS STYLE USE THESE DIMENSIONS

A	2-1/4" (57mm)
B	5-3/4" (146mm)

* IF YOUR FOUNTAIN IS THIS STYLE USE THESE DIMENSIONS

A	3-15/16" (100mm)
B	7-7/16" (189mm)

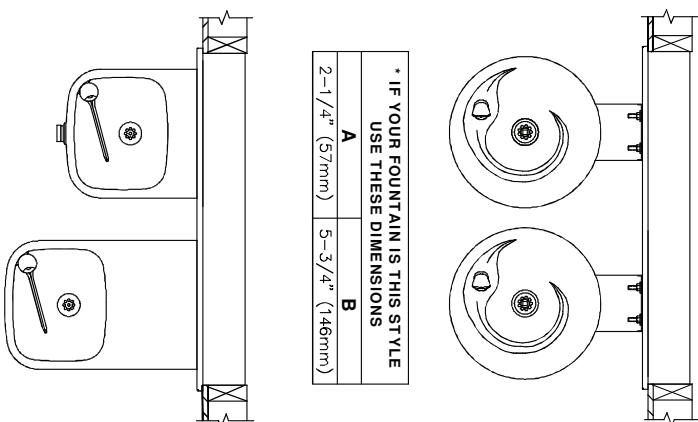

Haws Corporation

INFO FAX : 1-888-FAX-HAWS (1-888-329-4297)
 1455 Kieppe Ln, Sparks, NV, 89431
 Phone: 775-339-0112 Fax: 775-339-7424
 Haws Mtg Bldg 299 S. Boulder Blvd. Reno, NV 89502
 Haws Mtg Bldg 299 S. Boulder Blvd. Sparks, NV 89431
 e-mail: haws@hawsco.com website: www.hawsco.com

REG. NO. 1 REVISED PER BR. DATE: 05/97
 DWT/HOU
 MODEL(S): MTGFR/LG MOUNTING FRAME DUAL
 INFO FAX DOC # 2654
 SCALE: 1:16 DRAWING TYPE: INSTALLATION/BACKPACK

PART NUMBERS: 0002080318
 DRAWING NUMBER: 00665A00
 SHEET: A OF 1

©2006 Haws Corporation - All Rights Reserved HAWS® and other trademarks used in these materials are the exclusive property of Haws Corporation.

Doc. No. 06665A00

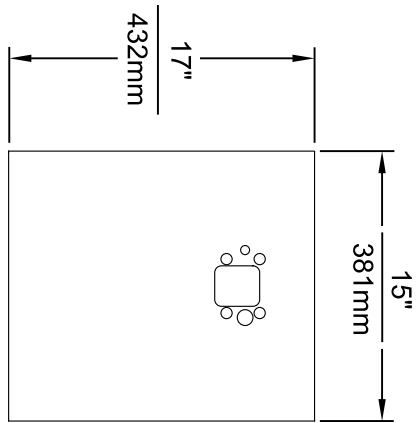

MODEL BP15 / BP15HPS / BP15W

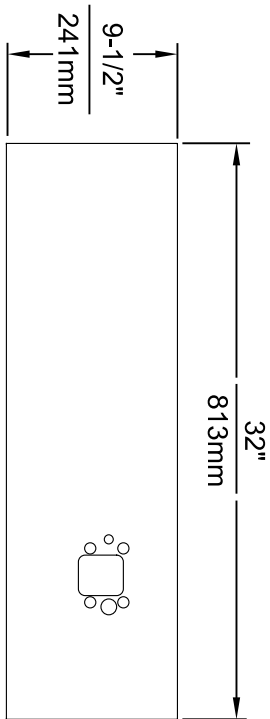
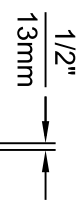

MODEL BP32 / BP32HPS / BP32W

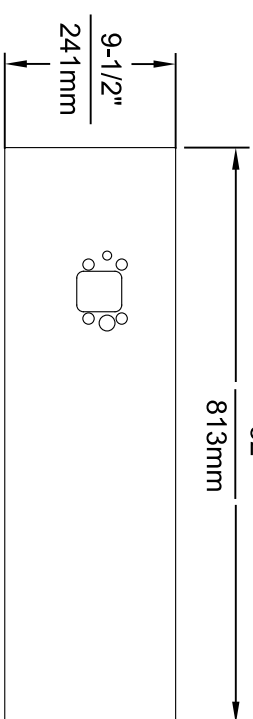
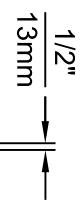

MODEL BP32R / BP32RW

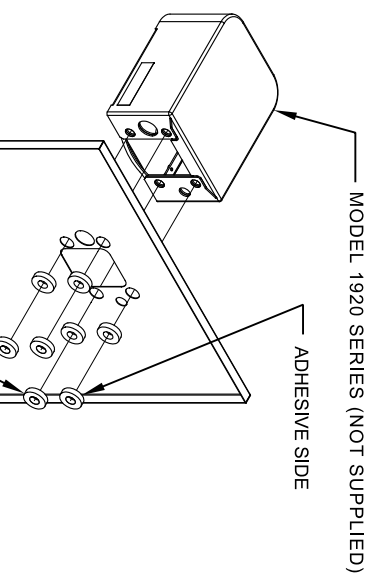
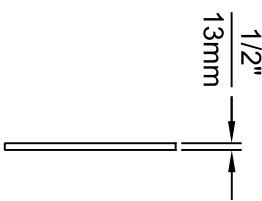

8 SPACERS (2 PER MOUNTING BOLT IF THE MOUNTING PLATE (MODEL 6700 - NOT SUPPLIED) IS INSTALLED BEHIND THE FINISHED WALL. USE 1 SPACER PER BOLT FOR RETROFITS WHERE THE MOUNTING PLATE (MODEL 6700R - NOT SUPPLIED) IS INSTALLED IN FRONT OF THE FINISHED WALL)

INSTALLATION OVER SINGLE FOUNTAIN

SHOWN FROM REAR
 (SEE SHEET 3 OF 3 FOR INSTALLATION OF SPACERS ON COMBINATION BOTTLE FILLER AND FOUNTAIN BACK PANELS FOR CHILD HEIGHT APPLICATIONS - MODELS BP15C & BP15WC)

- NOTES:
1. WHEN INSTALLING THIS UNIT, LOCAL, STATE OR FEDERAL CODES SHOULD BE ADHERED TO.
 2. BOTTLE FILLER SHOWN FOR REFERENCE ONLY (NOT SUPPLIED).

 <p>Haws Since 1906</p>		MODEL(S) DRAWING, BACK PANEL, SPACER INSTALLATION FOR BP15 SERIES & BP32 SERIES, BOTTLE FILLER	1455 KLEPPLELANE SPARKS, NEVADA 89431 (775) 359-4712 FAX (775) 359-7424 E-MAIL: HAWS@HAWSCO.COM WEBSITE: WWW.HAWSCO.COM
EGN NO. REVISED PER BY: 5081 EGN: 5972 FV	DATE: 06/27/16 JC DATE: 04/19/24	SCALE: 1:1 DRAWING TYPE: INSTALLATION	PART NUMBER: 0510000493 REVISION: 5

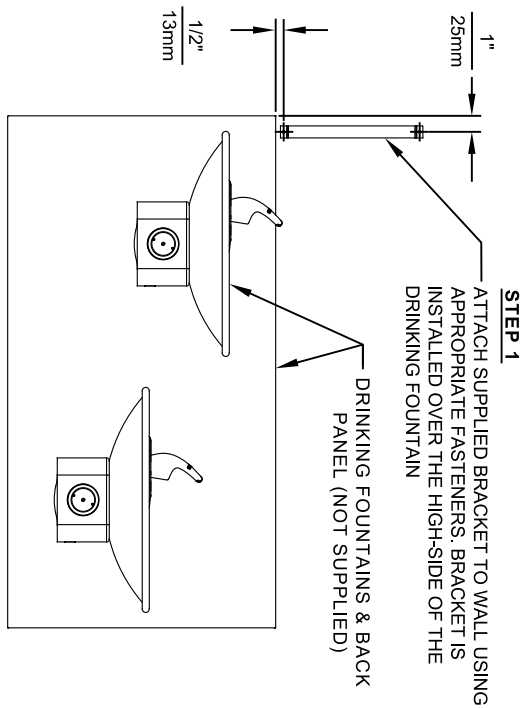

STEP 2
PLACE THE BACKPLATE AGAINST THE WALL AND SLIDE SIDEWAYS SO THE TABS CATCH UNDER THE BRACKET.

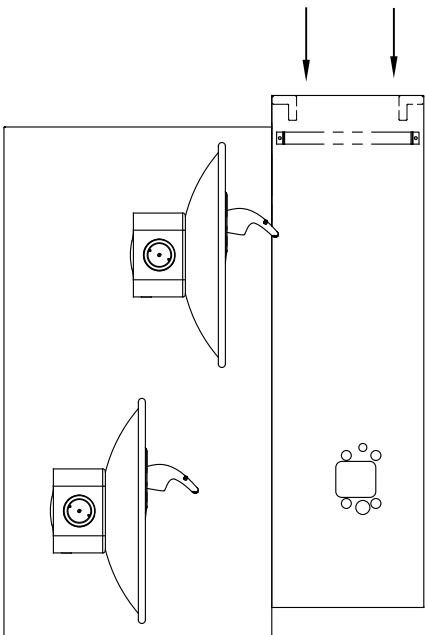

STEP 3
INSTALL THE BOTTLE FILLER (NOT SUPPLIED) PER THE INSTRUCTIONS SUPPLIED WITH THE UNIT.

- NOTES:
1. WHEN INSTALLING THIS UNIT, LOCAL, STATE OR FEDERAL CODES SHOULD BE ADHERED TO.
 2. BOTTLE FILLERS, DRINKING FOUNTAINS & DRINKING FOUNTAIN BACK PANELS SHOWN FOR REFERENCE ONLY (NOT SUPPLIED).

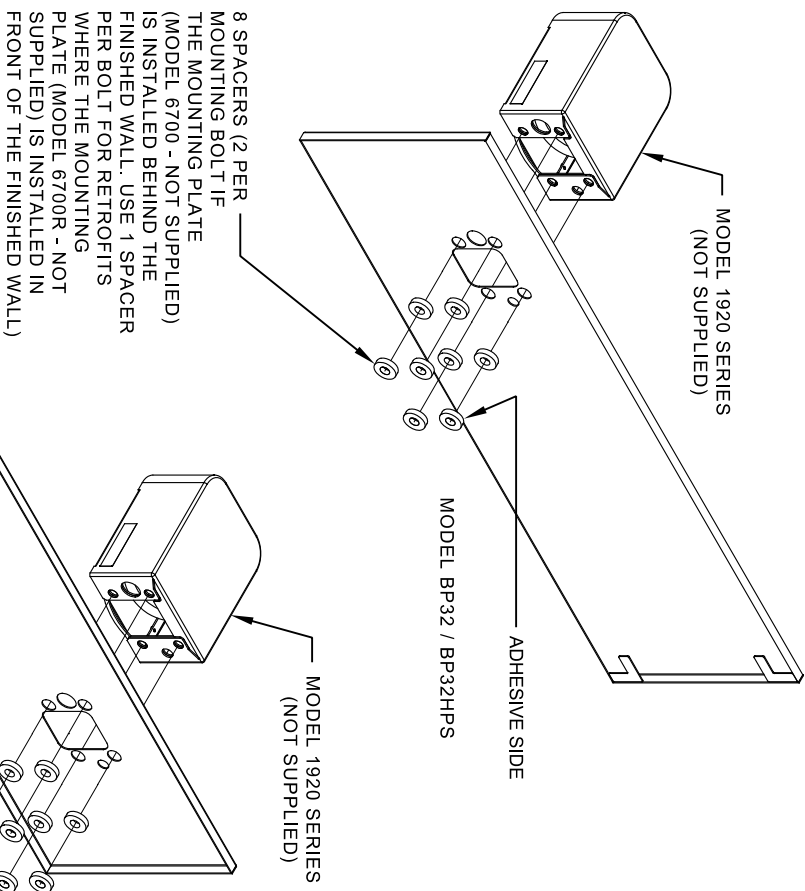

INSTALLATION OVER DOUBLE FOUNTAIN SHOWN FROM REAR

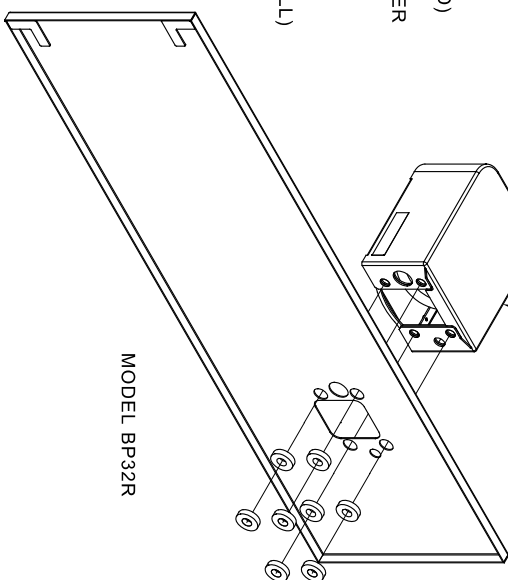

		MODEL(S) DRAWING, BACK PANEL, SPACER INSTALLATION FOR BP15 SERIES & BP32 SERIES, BOTTLE FILLER	
EGN NO. REVISED PER BY:	5081 FV	DATE:	04/19/24
DRAWN:	ECN: 3972	CHKD:	JC
DATE:	02/02/17	SCALE:	1:1
APPROVED:	FV	DRAWING TYPE:	INSTALLATION
1455 KLEPPLELANE SPARKS, NEVADA 89431 (775) 359-4712 FAX (775) 359-7424 E-MAIL: HAWS@HAWSCO.COM WEBSITE: WWW.HAWSCO.COM		Since 1906	PART NUMBER 0510000493 REVISION 5
SIZE: A1 SHEET: 2 OF 3			

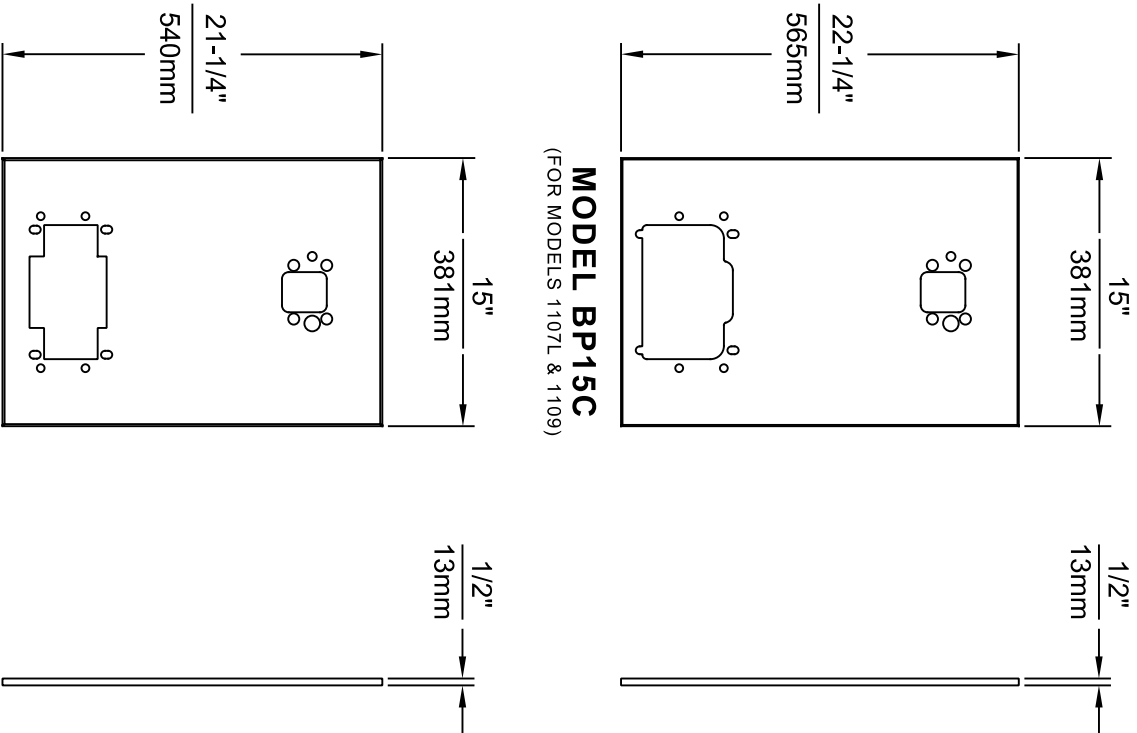

MODEL BP15WC
(FOR MODEL 1311)

- NOTES:
1. WHEN INSTALLING THIS UNIT, LOCAL, STATE OR FEDERAL CODES SHOULD BE ADHERED TO.
 2. BOTTLE FILLER AND DRINKING FOUNTAIN SHOWN FOR REFERENCE ONLY (NOT SUPPLIED).

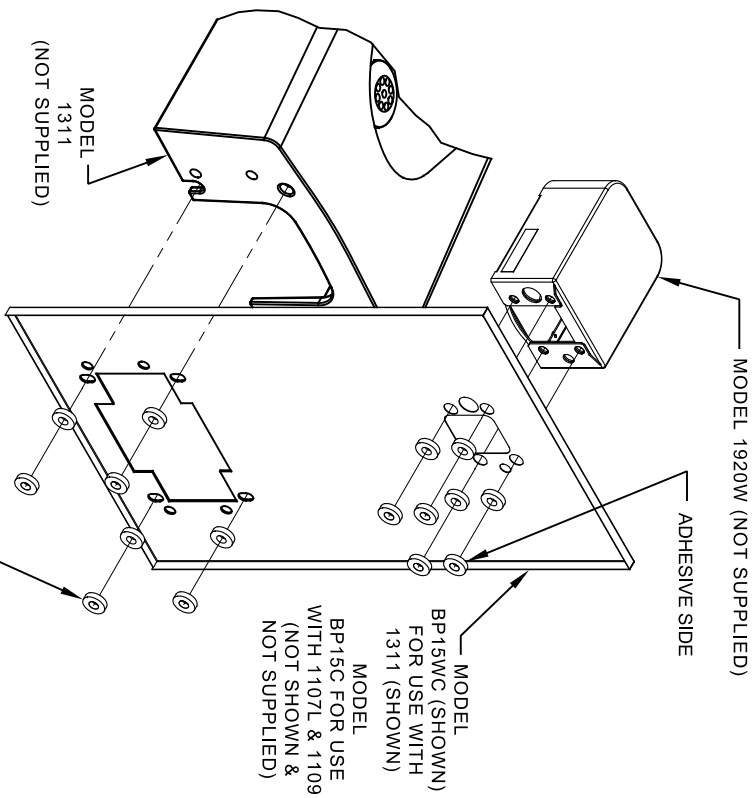

16 SPACERS (2 PER MOUNTING BOLT IF BOTH MOUNTING PLATES (MODEL 6700 - NOT SUPPLIED) ARE INSTALLED BEHIND THE FINISHED WALL. USE 1 SPACER PER BOLT FOR RETROFITS WHERE BOTH MOUNTING PLATES (MODEL 6700R - NOT SUPPLIED) ARE INSTALLED IN FRONT OF THE FINISHED WALL)

ONE PIECE INSTALLATION ON SINGLE FOUNTAIN

SHOWN FROM REAR

(MODEL BP15C & BP15WC ARE COMBINATION BOTTLE FILLER AND FOUNTAIN BACK PANELS USED FOR CHILD HEIGHT APPLICATIONS ONLY ON MODELS 1107L, 1109 & 1311 - BOTTLE FILLER & DRINKING FOUNTAIN NOT SUPPLIED)

 <p>Haws Since 1906</p>		<p>1455 KLEPPLELANE SPARKS, NEVADA 89431 (775) 359-4712 FAX (775) 359-4242 E-MAIL: HAWS@HAWSCO.COM WEBSITE: WWW.HAWSCO.COM</p>	
<p>EGN NO. 5972 DRAWN: FV DATE: 12/19/23</p>	<p>REVISED PER BY: FV ECON: 5972 DATE: 12/19/23</p>	<p>MODEL(S) DRAWING, BACK PANEL, SPACER INSTALLATION FOR BP15 SERIES & BP32 SERIES, BOTTLE FILLER</p>	<p>PART NUMBER 0510000493 REVISION 5</p>
<p>APPROVED: FV DATE: 04/19/24</p>	<p>SCALE: 1:1 DRAWING TYPE: INSTALLATION</p>	<p>SIZE: A1 SHEET 3 OF 3</p>	

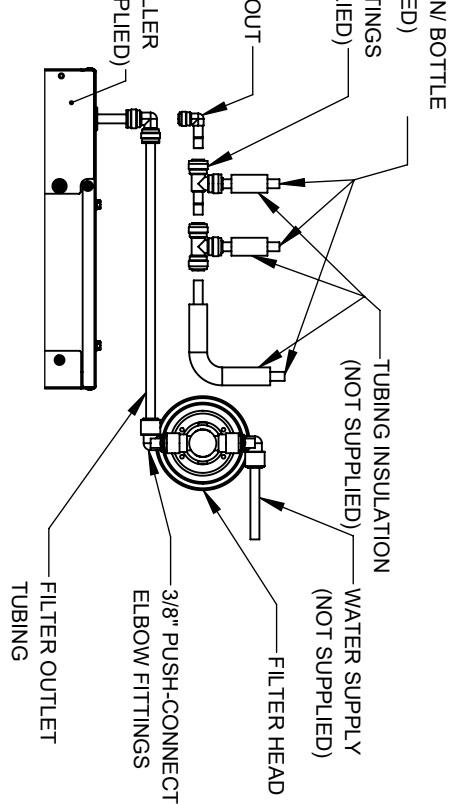
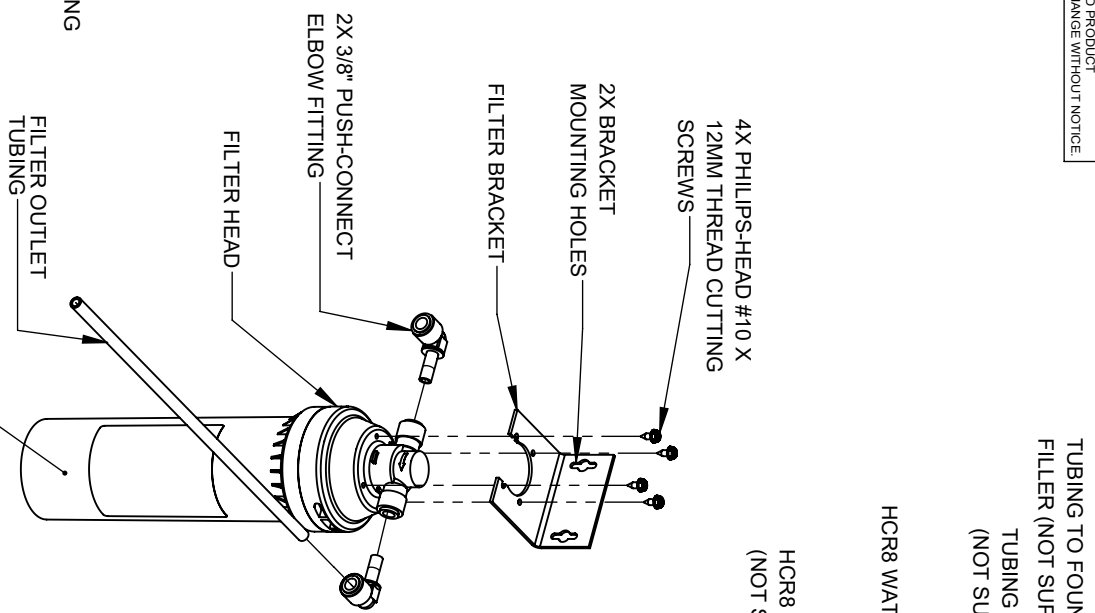
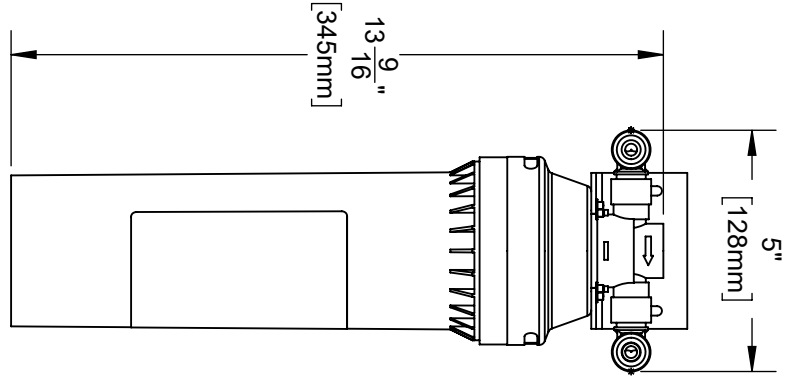

TYPICAL WATERWAY INSTALL WITH CHILLING UNIT
EXTRA COMPONENTS NOT INCLUDED

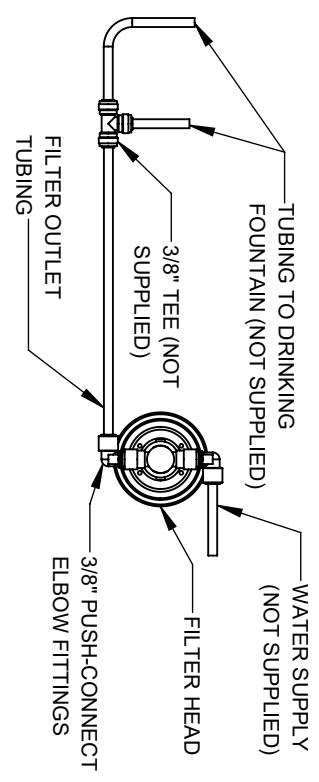

TYPICAL WATERWAY INSTALL WITHOUT CHILLER
EXTRA COMPONENTS NOT INCLUDED

INSTRUCTIONS

- STEP 1:** USE SCREWS (NOT SUPPLIED) TO MOUNT FILTER BRACKET TO VERTICAL SURFACE THAT IS ACCESSIBLE FOR SERVICING FILTER AND REPLACEMENT.
- STEP 2:** USE 4X PHILLIPS-HEAD #10 X 12MM THREAD CUTTING SCREWS TO SECURE FILTER HEAD TO FILTER BRACKET. ORIENT FLOW ARROW ACCORDINGLY.
- STEP 3:** INSERT 2X 3/8" PUSH-CONNECT ELBOW FITTINGS INTO FILTER HEAD. INSERT FULLY.

- STEP 4:** INSERT FILTER INTO FILTER HEAD ACCORDING TO NOTCHES ON INSIDE OF HEAD AND TOP OF FILTER AND MAKE 1/4 TURN UNTIL FILTER IS SECURE.

FILTER KIT INSTALL

		1455 KLEPPE LANE SPARKS, NEVADA, 89431	
Since 1906		(775) 359-4712 FAX (775) 359-7424	
E-MAIL: HAWS@HAWS.CO.COM		WEBSITE: WWW.HAWS.CO.COM	
REV. E.C.N. 6016	REV. E.C.N. BY: J.G.	MODEL(S) 6480	PART NUMBER 0510002217.D
DATE 04/24/16	DATE 04/24/16	UNIVERSAL FILTER KIT	REVISION 3
APPROVED: F.V.	DATE 10/22/24	SCALE: 1:12	DRAWING TYPE: INSTALLATION
		SIZE: A	SHEET 1 OF 2

FILTER REPLACEMENT SHEET

To ensure maximum benefit from your Haws Filter, track installations and replacements on this sheet according to the guidelines listed below.

REPLACEMENT FILTER

Haws Part No. 6428

Change filter every 3,000 gallons or once a year - whichever occurs first

INSTALLATION DATE	SERVICE PERSON	INSTALLATION DATE	SERVICE PERSON

 Haws [®] Since 1906	1455 KLEPPE LANE
	SPARKS, NEVADA 89431
	(775) 359-4712 FAX (775) 359-7424
	E-MAIL: HAWS@HAWS.CO.COM WEBSITE: WWW.HAWS.CO.COM

6700 INDEX

INSTALLATION WITH:	TYPICAL USES	SEE SHEET...	
GENERAL INSTALLATION		IMPORTANT INFORMATION FOR ALL INSTALLATIONS	3 OF 6
1001 BOWLS	HAWS SERIES 1001X, 1001.8X		3 OF 6
1107 BOWLS	HAWS SERIES 1107X, 1107.8X		3 OF 6
1109 BOWLS	HAWS SERIES 1109X, 1109.8X		3 OF 6
1047 BOWLS	HAWS SERIES 1047		4 OF 6
1011 BOWLS	HAWS SERIES 1011X, 1011.8X		4 OF 6
1119 BOWLS	HAWS SERIES 1119X, 1119.8X		4 OF 6
1117 BOWLS	HAWS SERIES 1117X, 1117.8X	5 OF 6	
1311 BOWLS	HAWS SERIES 1311	5 OF 6	
1501 BOWLS	HAWS SERIES 1501	5 OF 6	
CHILD HEIGHT	HAWS 1107PCH, 1109PCH, 1311PCH	6 OF 6	

 <p>Haws Since 1906</p>		1455 KLEPPE LANE SPARKS, NEVADA 89431 (775) 359-4712 FAX (775) 359-7424 E-MAIL: HAWS@HAWSCO.COM WEBSITE: WWW.HAWSCO.COM	
ECN NO. REVISED PER BY:	MODEL(S)	SCALE:	DRAWING TYPE:
ECN: 6148		N/A	
DATE: 10/03/24	67/00		
CHKD: JG			
DATE: 02/11/25			
CHKD: JG			
DATE: 02/11/25			
APPROVED: FV			
INSTALLATION	SIZE: A	SHEET	1 OF 6
PART NUMBER	0002080016	REVISION	26

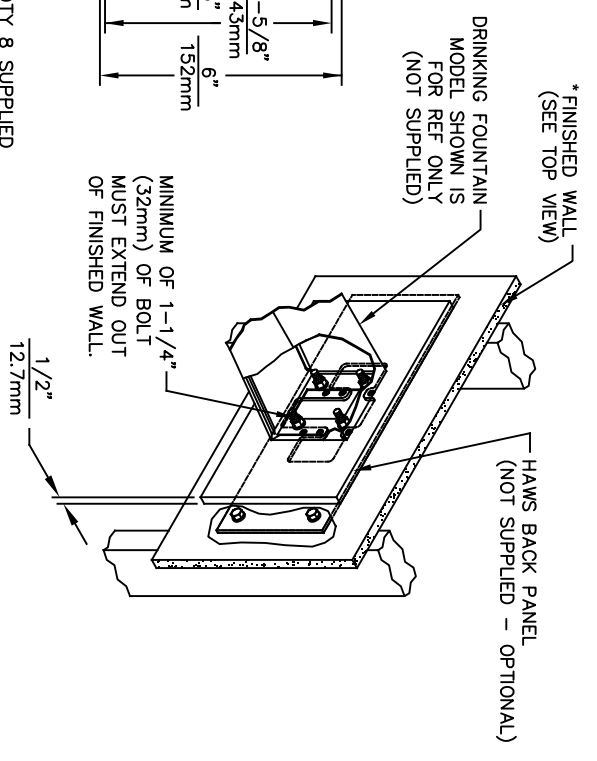
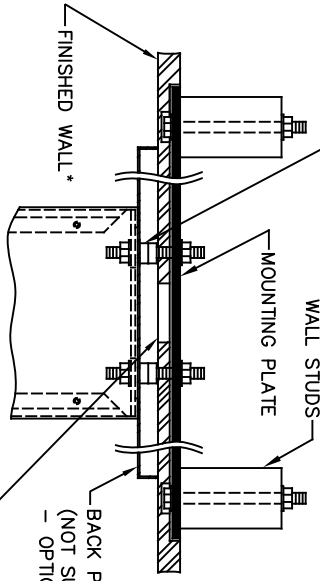
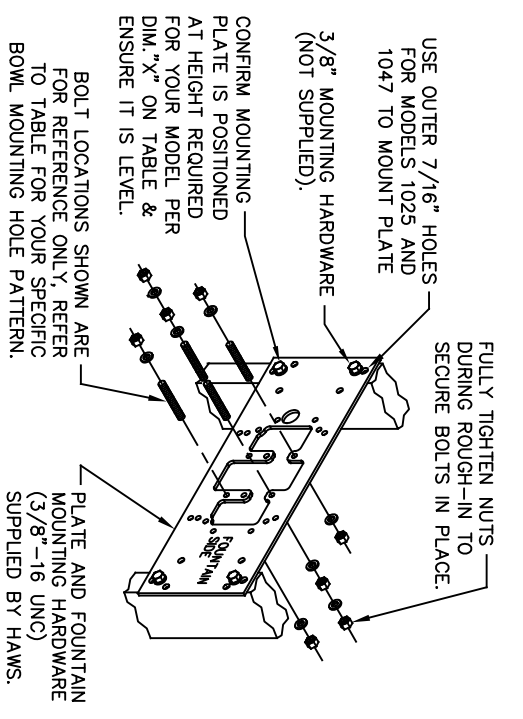
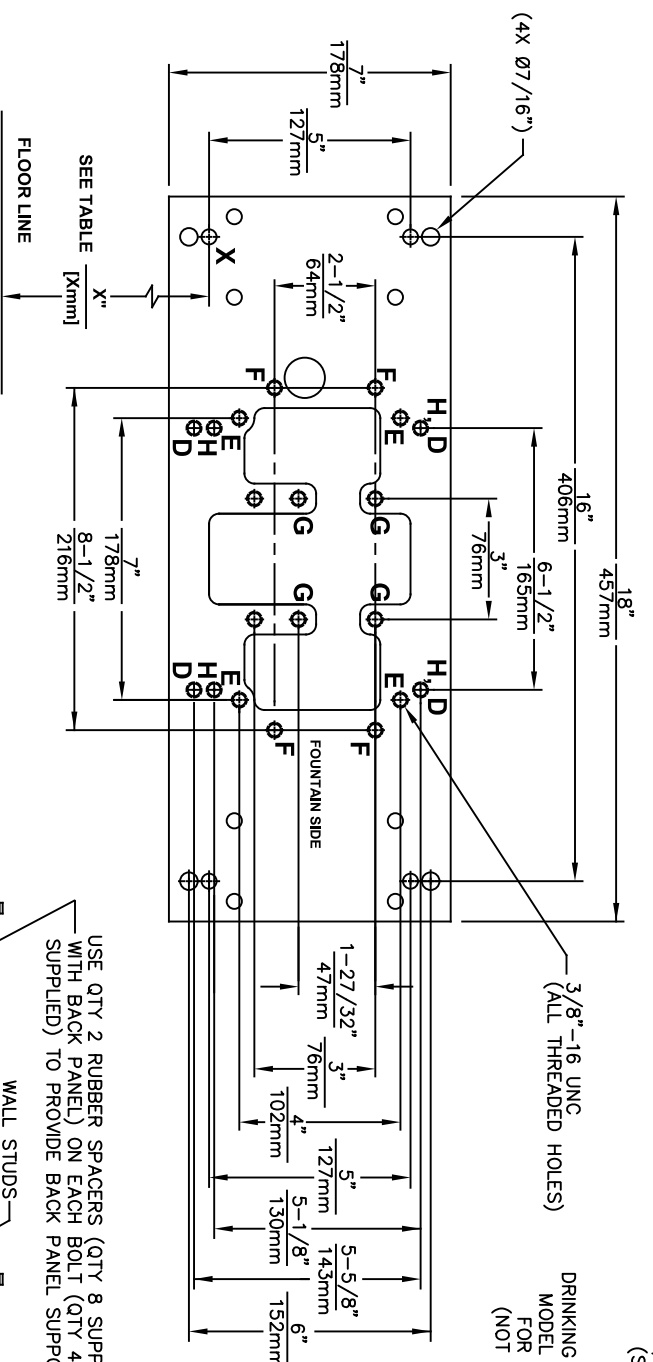

CAUTION

REGARDING CONCRETE/MASONRY WALL MOUNTING: DO NOT SECURE MOUNTING PLATE TO SAME SIDE OF WALL AS FOUNTAIN. AVOID COMPROMISING INTEGRITY OF WALL WHEN ANCHORING FOUNTAIN. IT IS RECOMMENDED THAT INSTALLER CALL TECHNICAL SUPPORT IF THERE ARE ANY QUESTIONS AS TO HOW TO OBTAIN A PROPER ANCHOR IN CONCRETE/MASONRY WALLS. 1-800-766-5612

TOP VIEW
 6700 MOUNTING PLATE
 FOR USE WITH
 DRINKING FOUNTAINS
 AND WASTE DRIP TRAYS
 AT 27" ADULT HEIGHT
 (SEE SHEETS 2 - 5 FOR USE WITH
 BOTTLE FILLER 1920/1920HO SERIES
 AND CHILD HEIGHT APPLICATIONS)

* FINISH WALL OVER MOUNTING PLATE AND BEHIND BACK PANEL. MAKE SURE THAT FINISHED WALL EXTENDS WITHIN THE BRACKET/BOWL MOUNTING HOLES (TO PROVIDE SURFACE AREA FOR RUBBER SPACERS TO CONTACT).

MODEL	USE BOWL MTG. HOLE PATTERN	USE "X" DIM. BELOW TO POSITION MOUNTING PLATE HOLE "X"
1001	"G"	25-3/8" [645mm]
1025	"D"	28-1/8" [714mm]
1047	"E"	24-3/8" [619mm]
1105	"H"	34-5/16" [872mm]
1107	"F"	26-3/16" [665mm]
1109	"H"	27-5/16" [694mm]
1109.14	"H"	27-5/16" [694mm]
1109FR	"H"	27-5/16" [694mm]
1311	"E"	26-3/4" [679mm]

WASTE DRIP TRAY (ONLY) AT 27" ADULT HEIGHT	PART NUMBER
"G"	6468
"G"	1922

1455 KLEPPE LANE
 SPARKS, NEVADA 89431
 (775) 369-4712 FAX (775) 359-7424
 E-MAIL: HAWS@HAWS.CO.COM
 WEBSITE: WWW.HAWS.CO.COM

ECN NO. / REVISED PER BY: / DATE: / CHK'D: / DATE: / APPROVED: / DATE: / SCALE: / N/A / DRAWING TYPE: / INSTALLATION: / SIZE: A / SHEET: 2 OF 6

MODEL(S) 6700

REVISION 26

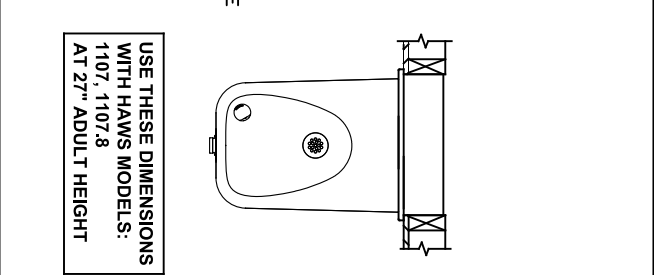
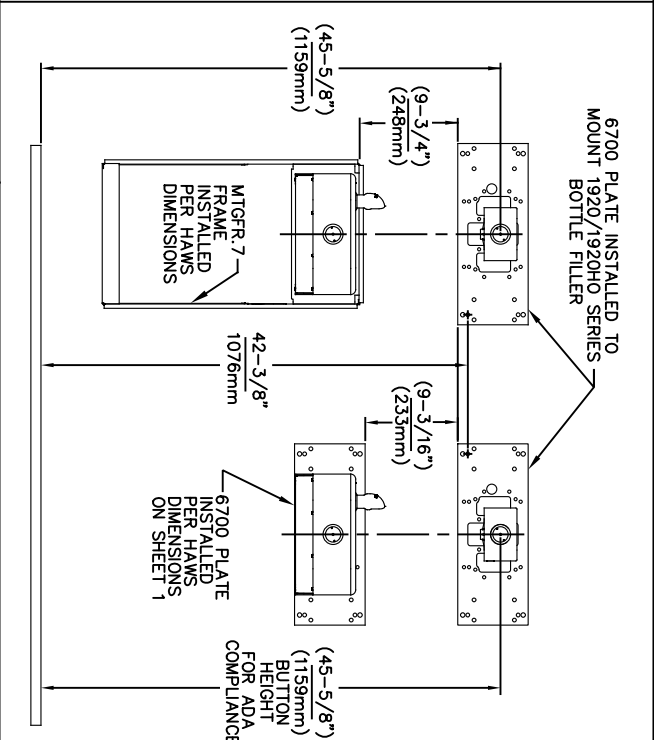
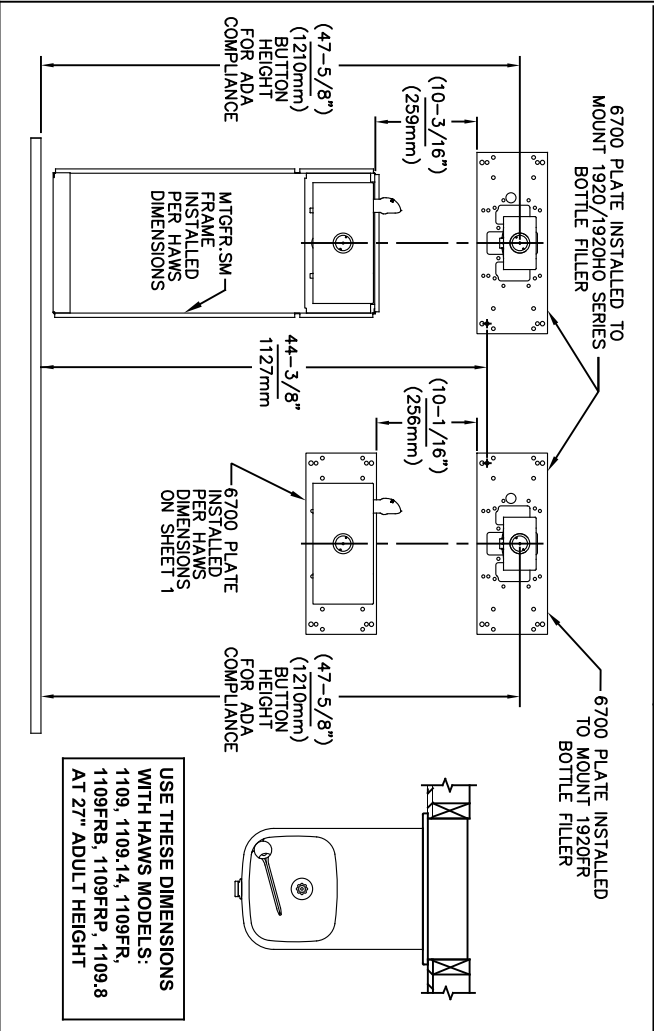
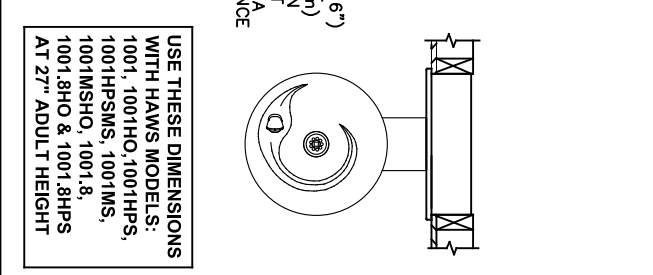
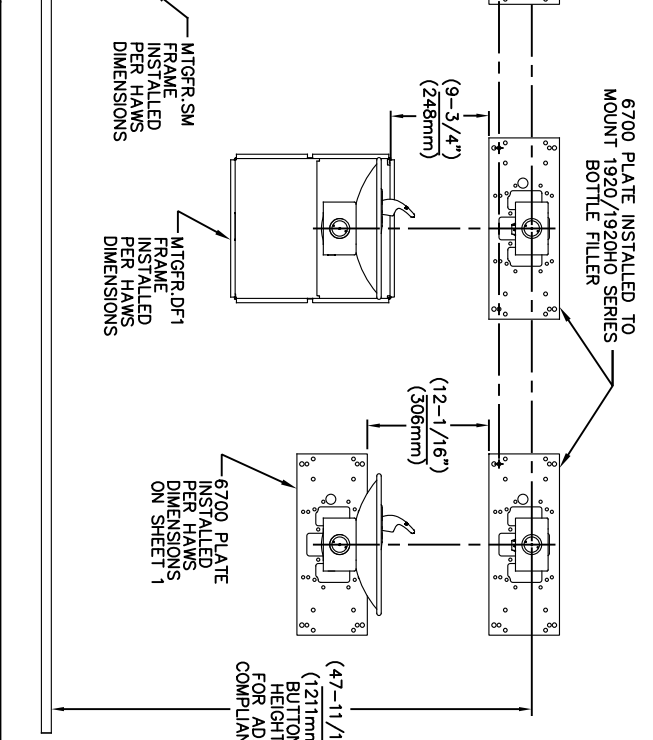
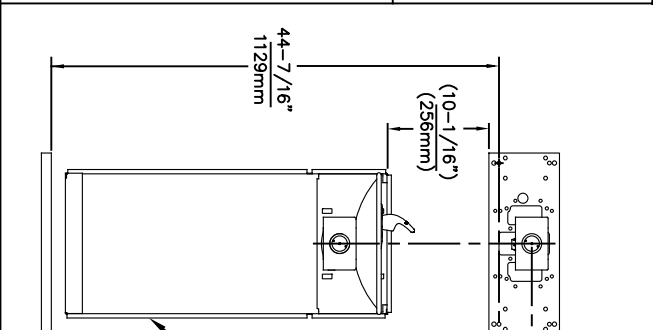
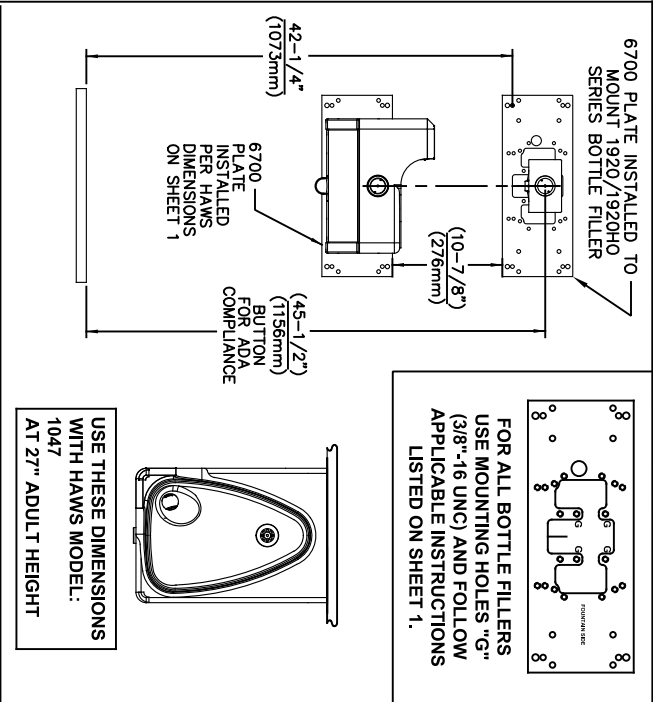

NOTES:
 1. WHEN INSTALLING THIS UNIT, LOCAL, STATE OR FEDERAL CODES SHOULD BE ADHERED TO.
 2. BACK PANELS (OPTIONAL) NOT SHOWN FOR CLARITY.

6700 MOUNTING PLATE
 FOR USE WITH BOTTLE FILLER
 (SEE SHEET 1 FOR USE WITH
 DRINKING FOUNTAINS)

1455 KLEPPE LANE
 SPARKS, NEVADA 89431
 (775) 359-4712 FAX (775) 359-7424
 E-MAIL: HAWS@HAWS.CO.COM
 WEBSITE: WWW.HAWS.CO.COM

ECN NO. REVISED PER BY:	MODEL(S)
ECN 6148 JG	6700
DATE: 02/09/17	
CHK'D: JG	
DATE:	
APPROVED: EV	SCALE: N/A
DATE: 02/11/25	DRAWING TYPE: INSTALLATION
SIZE: A	SHEET: 3 OF 6
PART NUMBER: 0002080016	REVISION: 26

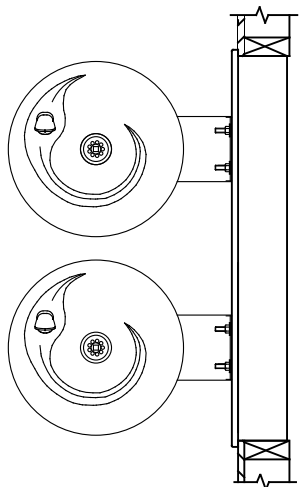
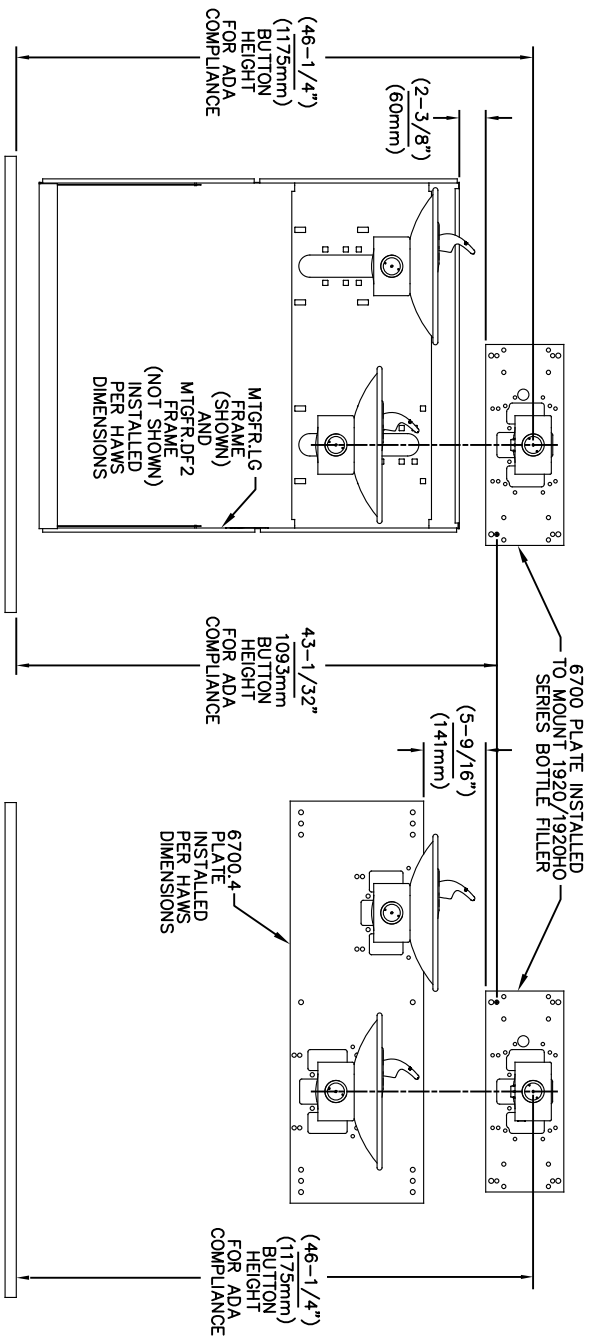

USE THESE MOUNTING DIMENSIONS IF INSTALLING OVER HAWS FOUNTAIN
 MODEL: 1011, 1011HO, 1011HO2, 1011HPS, 1011HPSHO, 1011HPSHO2, 1011HPSMS, 1011MS, 1011MSHO, 1011MSHO2, 1011.8, 1011.8HO, 1011.8HO2 & 1011.8HPSMS AT 27" ADULT HEIGHT
 INSTALL THE 6700 ABOVE THE FOUNTAIN MOUNTING PLATE OR FRAME AT THE DIMENSION SHOWN FOR CORRECT BACKPANEL SPACING
BACK PANELS FOR BOTTLE FILLERS (NOT SUPPLIED - OPTIONAL) ARE NOT SHOWN FOR CLARITY.

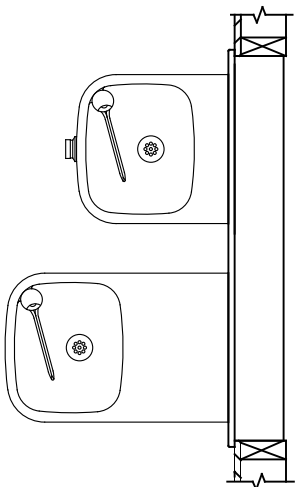
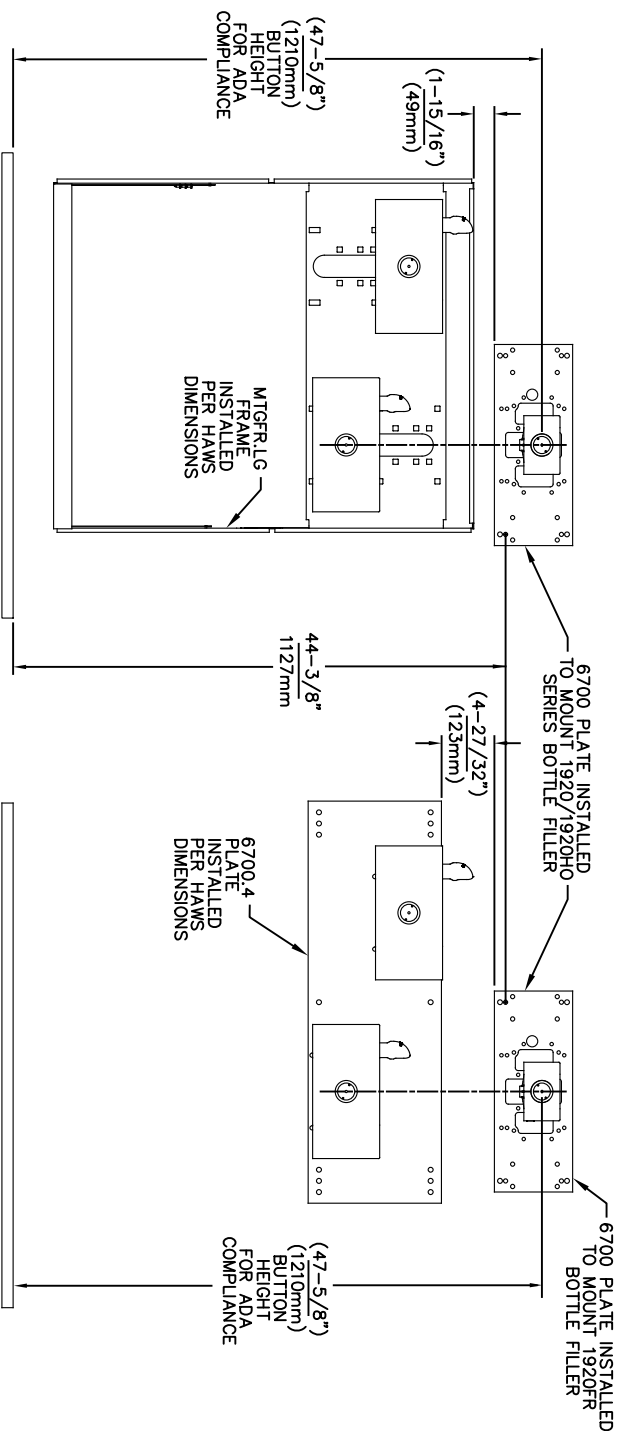

USE THESE MOUNTING DIMENSIONS IF INSTALLING OVER HAWS FOUNTAIN
 MODEL: 1119, 1119.14, 1119.14HO, 1119.14HO2, 1119FR, 1119FRB, 1119FRP, 1119HO, 1119HO2 & 1119.8 AT 27" ADULT HEIGHT
 INSTALL THE 6700 ABOVE THE FOUNTAIN MOUNTING PLATE OR FRAME AT THE DIMENSION SHOWN FOR CORRECT BACKPANEL SPACING
BACK PANELS FOR BOTTLE FILLERS (NOT SUPPLIED - OPTIONAL) ARE NOT SHOWN FOR CLARITY.

- NOTES:
 1. WHEN INSTALLING THIS UNIT, LOCAL, STATE OR FEDERAL CODES SHOULD BE ADHERED TO.
 2. BACK PANELS (OPTIONAL) NOT SHOWN FOR CLARITY.

6700 MOUNTING PLATE
 FOR USE WITH BOTTLE FILLER
 (SEE SHEET 1 FOR USE WITH
 DRINKING FOUNTAINS)

Haws
 Since 1906

ECON. NO. REVISED PER BY:		MODEL(S)	
5550	ECON. 6148 JG	6700	
DATE: 05/14/20	CHKD. JG		
APPROVED: FV	DATE: 02/11/25	SCALE: 1:13	DRAWING TYPE: INSTALLATION
1459 KLEPPE LANE SPARKS, NEVADA, 89431 (775) 359-4712 FAX (775) 359-7424 E-MAIL: HAWS@HAWS.CO.COM WEBSITE: WWW.HAWS.CO.COM		PART NUMBER 0002080016 REVISION: 26	

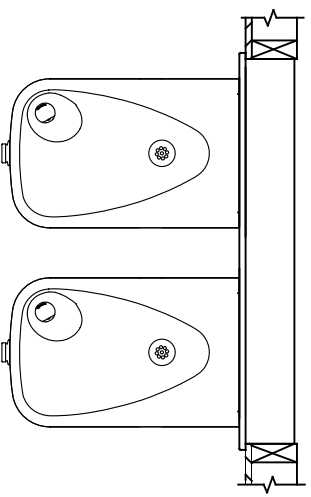
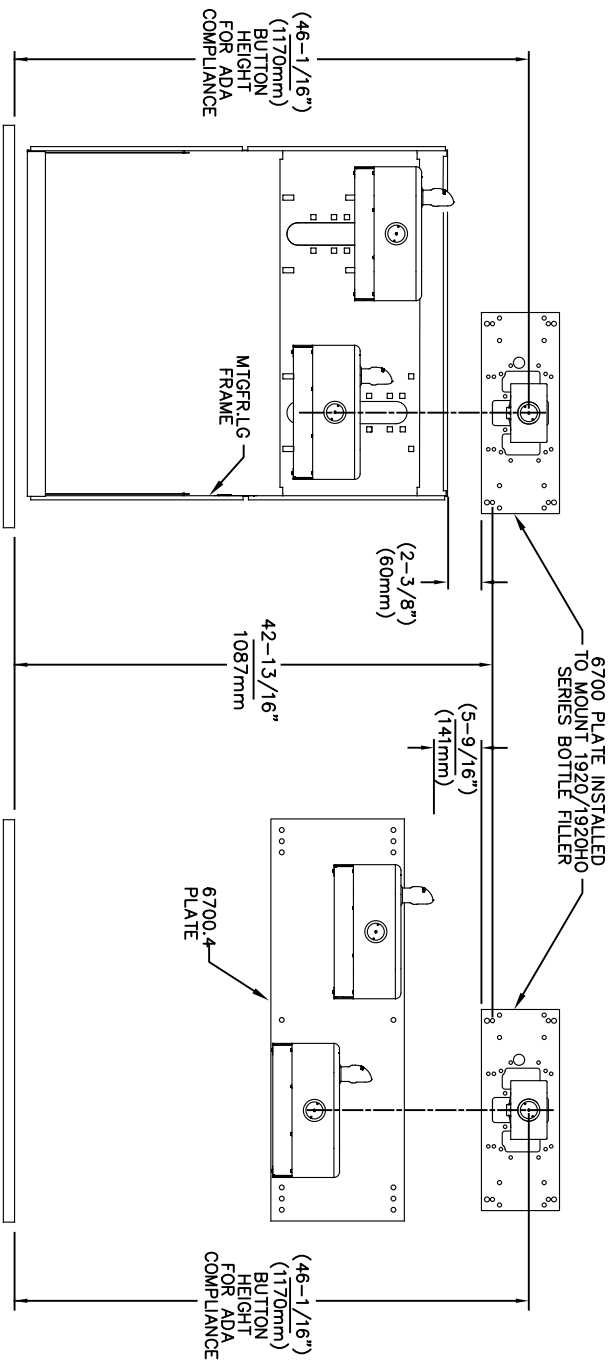

USE THESE MOUNTING DIMENSIONS IF INSTALLING OVER HAWS FOUNTAIN MODEL: 1117, 1117.8 AT 27" ADULT HEIGHT

INSTALL THE 6700 ABOVE THE FOUNTAIN MOUNTING PLATE OR FRAME AT THE DIMENSION SHOWN FOR CORRECT BACKPANEL SPACING

BACK PANELS FOR BOTTLE FILLERS (NOT SUPPLIED - OPTIONAL) ARE NOT SHOWN FOR CLARITY.

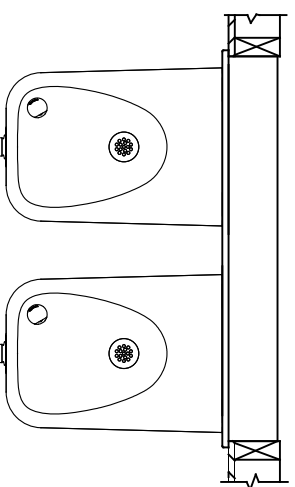
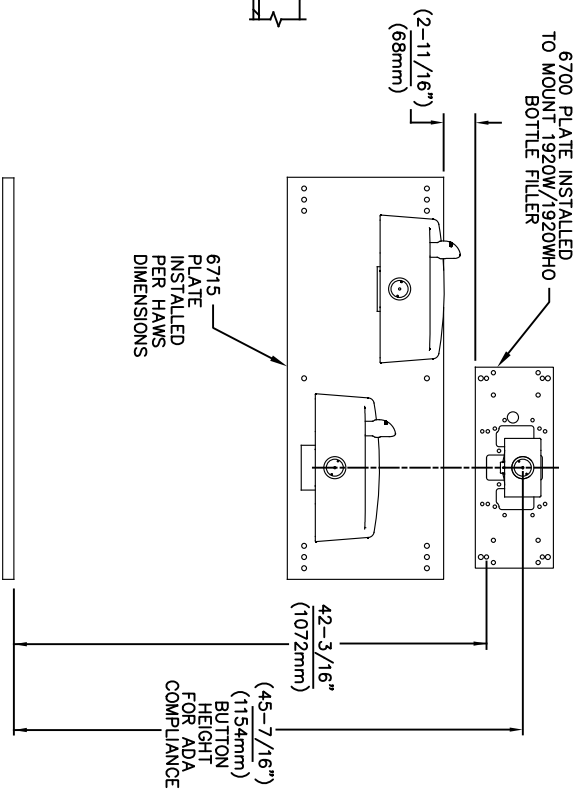
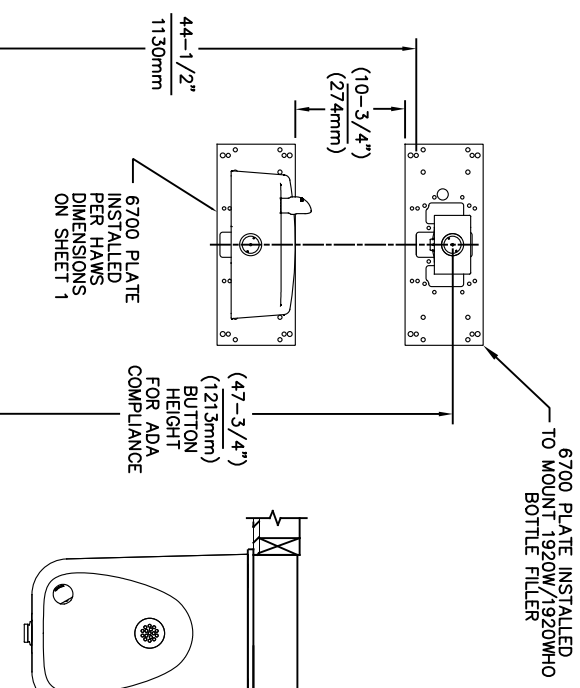

USE THESE MOUNTING DIMENSIONS IF INSTALLING OVER HAWS FOUNTAIN MODEL: 1311, 1501 AT 27" ADULT HEIGHT

INSTALL THE 6700 ABOVE THE FOUNTAIN MOUNTING PLATE AT THE DIMENSION SHOWN FOR CORRECT BACKPANEL SPACING (IF APPLICABLE). BACK PANEL FOR BOTTLE FILLER (NOT SUPPLIED - OPTIONAL) IS NOT SHOWN FOR CLARITY.

- NOTES:
1. WHEN INSTALLING THIS UNIT, LOCAL, STATE OR FEDERAL CODES SHOULD BE ADHERED TO.
 2. BACK PANELS (OPTIONAL) NOT SHOWN FOR CLARITY.

6700 MOUNTING PLATE FOR USE WITH BOTTLE FILLER (SEE SHEET 1 FOR USE WITH DRINKING FOUNTAINS)

		1459 KLEPPE LANE SPARKS, NEVADA, 89431 (775) 359-4712 FAX (775) 359-7424 E-MAIL: HAWS@HAWS.CO.COM WEBSITE: WWW.HAWS.CO.COM	
ECN NO. REVISED PER BY:	MODEL(S)	PART NUMBER	
5550		0002080016	
DATE: 05/14/20	DATE: JG	REVISION:	
DATE: JG	DATE: JG	26	
APPROVED: FV	SCALE: 1:13	DRAWING TYPE:	INSTALLATION
DATE: 02/11/25			SHEET 5 OF 6

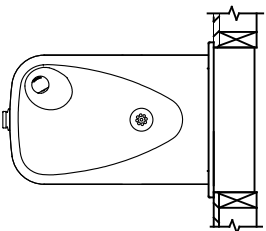
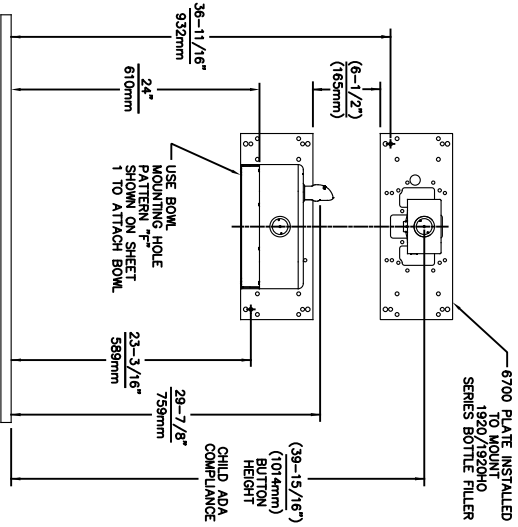

USE THESE DIMENSIONS WITH HAWS MODEL 1107PCH AT 24" CHILD HEIGHT *

6700 MOUNTING PLATE FOR USE WITH BOTTLE FILLER AT 40" MAX. AND DRINKING FOUNTAIN AT 24" AND BUBBLER HEIGHT AT 30" MAX. FOR CHILD ADA HEIGHT (SEE SHEETS 1 & 2 FOR USE WITH DRINKING FOUNTAIN AT 27" ADULT HEIGHT DIMENSIONS)

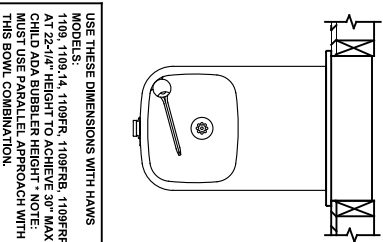
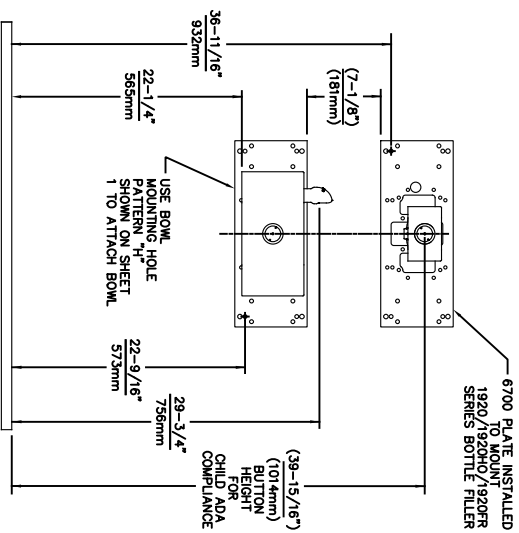

USE THESE DIMENSIONS WITH HAWS MODEL: 1109, 1109.14, 1109FR, 1109FRB, 1109FRP AT 22-1/4" HEIGHT TO ACHIEVE 30" MAX. CHILD ADA BUBBLER HEIGHT * NOTE: MUST USE PARALLEL APPROACH WITH THIS BOWL COMBINATION.

NOTES:
1. WHEN INSTALLING THIS UNIT, LOCAL, STATE OR FEDERAL CODES SHOULD BE ADHERED TO.
2. ONE PIECE BACK PANELS BP15C (FOR USE WITH MODELS 1107L, 1109 SERIES & BOTTLE FILLER) & BP15WC (FOR USE WITH MODEL 1311 & BOTTLE FILLER) ARE USED FOR CHILD HEIGHT APPLICATIONS AND ARE OPTIONAL (NOT SHOWN FOR CLARITY).

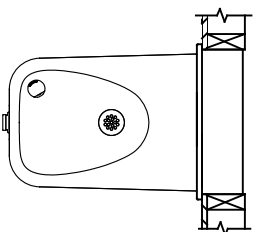
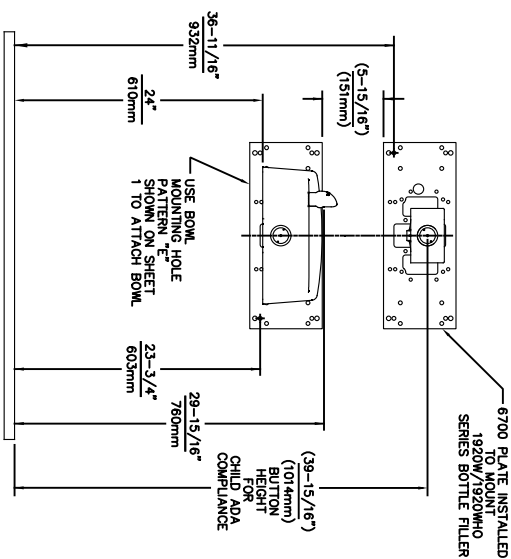

USE THESE DIMENSIONS WITH HAWS MODEL 1107PCH AT 24" CHILD HEIGHT *

6700 MOUNTING PLATE FOR USE WITH BOTTLE FILLER AT 40" MAX. AND DRINKING FOUNTAIN AT 24" AND BUBBLER HEIGHT AT 30" MAX. FOR CHILD ADA HEIGHT (SEE SHEETS 1 & 4 FOR USE WITH DRINKING FOUNTAIN AT 27" ADULT HEIGHT DIMENSIONS)

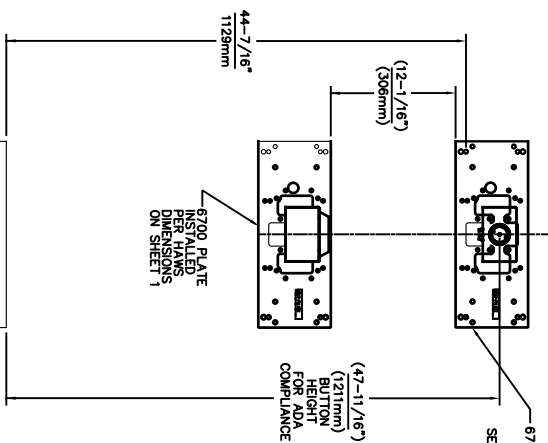

USE THESE MOUNTING DIMENSIONS IF INSTALLING OVER HAWS WASTE DRIP TRAY. MODEL: 6468 (SHOWN), 1922 (MODEL 1922 INCLUDES 1920 BOTTLE FILLER). THE 1920 BOTTLE FILLER BP15C BACK PANELS (NOT SHOWN), AT 27" ADULT HEIGHT.

INSTALL THE 6700 ABOVE THE DRIP TRAY MOUNTING PLATE AT THE DIMENSION SHOWN FOR CORRECT BACK PANEL SPACING (IF APPLICABLE). BACK PANEL FOR BOTTLE FILLER (NOT SUPPLIED - OPTIONAL) IS NOT SHOWN FOR CLARITY.

6700 MOUNTING PLATE FOR USE WITH BOTTLE FILLER (SEE SHEET 1 FOR USE WITH DRINKING FOUNTAINS AND WASTE DRIP TRAY)

Since 1906

1459 KLEPPE LANE
SPARKS, NEVADA, 89431
(775) 359-4712 FAX (775) 359-7424
E-MAIL: HAWS@HAWSCO.COM
WEBSITE: WWW.HAWSCO.COM

ECN NO. REVISED PER BY:	MODEL(S)
5893 1	6700
DATE: 07/26/23	SCALE: 1:13
CHKD: JG	DRAWING TYPE:
DATE: 02/11/25	INSTALLATION:
APPROVED: FV	SHEET 6 OF 6

PART NUMBER: 0002080016
REVISION: 26

1920 INDEX

INSTALLATION WITH:	TYPICAL USES	SEE SHEET ...
1001/1011 BOWLS	HAWS SERIES 1001, H1001.8X, 1011, 1011.8X STYLE FOUNTAINS	3 DF 9
1109/1119 BOWLS		4 DF 9
1107/1117 BOWLS		5 DF 9
1311/1501 BOWLS		6 DF 9
1047		7 DF 9
6468		8 DF 9
CHILD HEIGHT	HAWS 1107P STD CONFIG CHILD HEIGHT, 1109P STD CONFIG CHILD HEIGHT, 1311P STD CONFIG CHILD HEIGHT	9 DF 9



Haws
Since 1906

1455 KLEPPE LANE
SPARKS, NEVADA 89431
(775) 359-4712 FAX (775) 359-7424
E-MAIL: HAWS@HAWSCO.COM
WEBSITE: WWW.HAWSCO.COM

EQN NO. REVISED PER BY: _____ MODEL(S) _____
 DRAWN BY: _____ DATE: _____
 APPROVED: _____ DATE: 11/28/24

SCALE: N/A DRAWING TYPE: _____ INSTALLATION: _____ SIZE: A SHEET 1 OF 9

PART NUMBER: 0510000490.D
REVISION: 13

1920/1920HPS/1920W

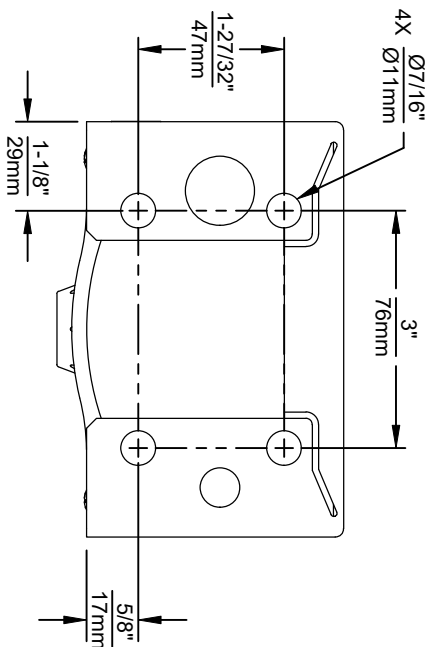
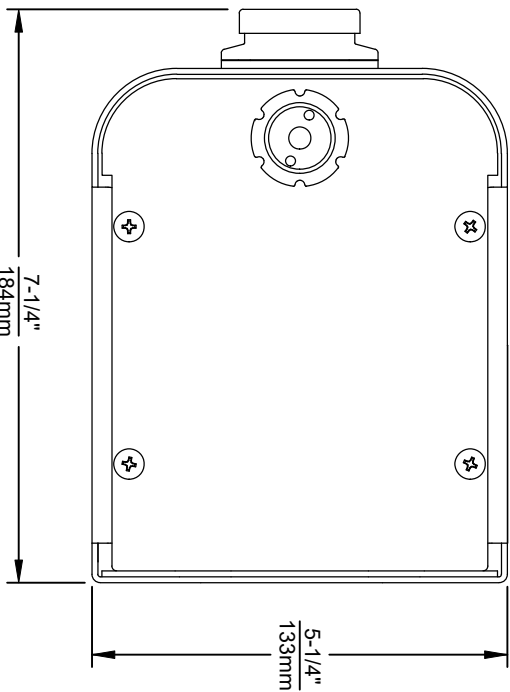
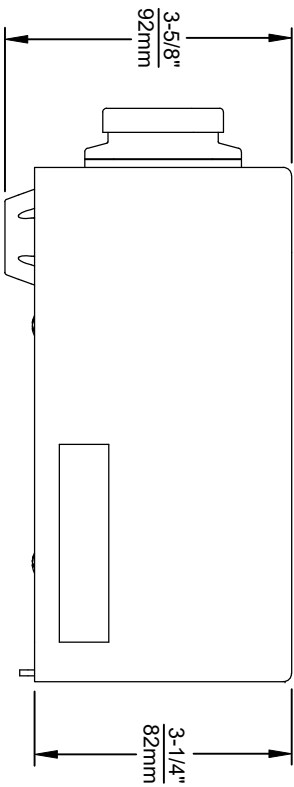

1920 SERIES MOUNTING HOLE LOCATIONS
(3/8\"-16 UNC MOUNTING HARDWARE NOT SUPPLIED)

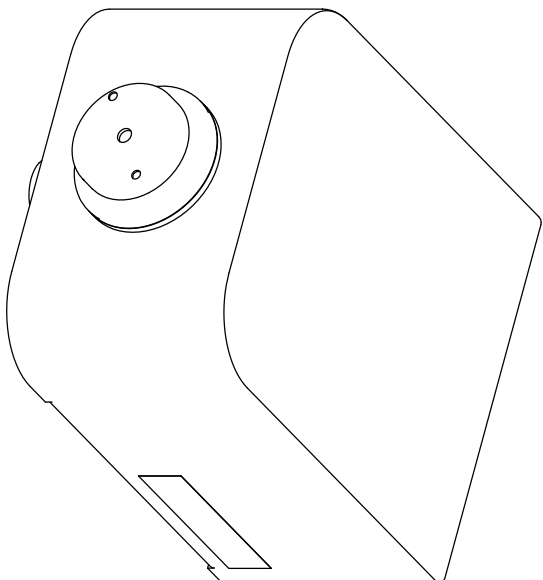

NOTES:

1. SEE SHEETS 2 THRU 7 FOR BOTTLE FILLER ADULT ADA HEIGHT APPLICATIONS AND SHEET 8 FOR CHILD ADA HEIGHT APPLICATIONS.
2. WHEN INSTALLING THIS UNIT, LOCAL, STATE OR FEDERAL CODES SHOULD BE ADHERED TO FOR INSTALLATION LOCATIONS, WASTE & SUPPLY REQUIREMENTS OTHER THAN SHOWN.

		Since 1906	
1455 KLEPPE LANE SPARKS, NEVADA 89431 (775) 359-4712 FAX (775) 359-7424 E-MAIL: HAWS@HAWSCO.COM WEBSITE: WWW.HAWSCO.COM		MODEL(S) 1920/1920HPS/1920W	
EQN NO. REVISED PER BY:	DATE	SCALE: N/A	DRAWING TYPE: INSTALLATION
DRW NO. DATE	CHG. JG	SIZE: A	SHEET 2 OF 9
APPROVED: RH	DATE: 11/29/24		
PART NUMBER	REVISION		
0510000490.D	13		

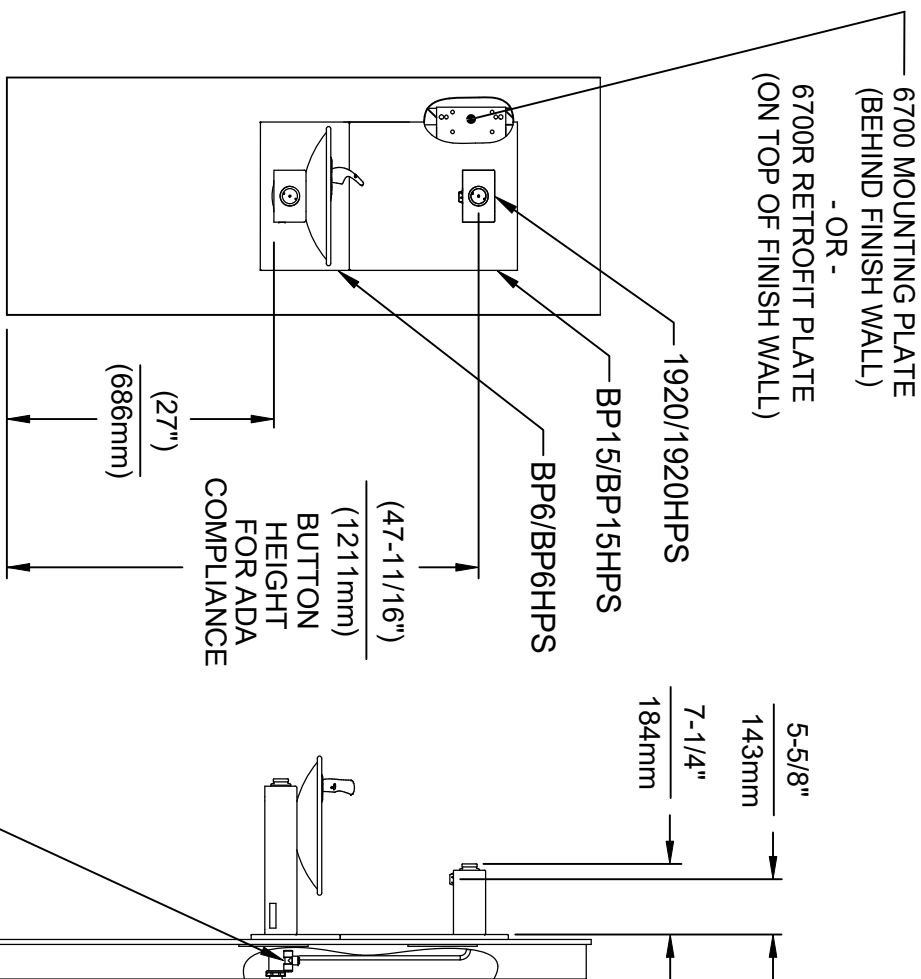
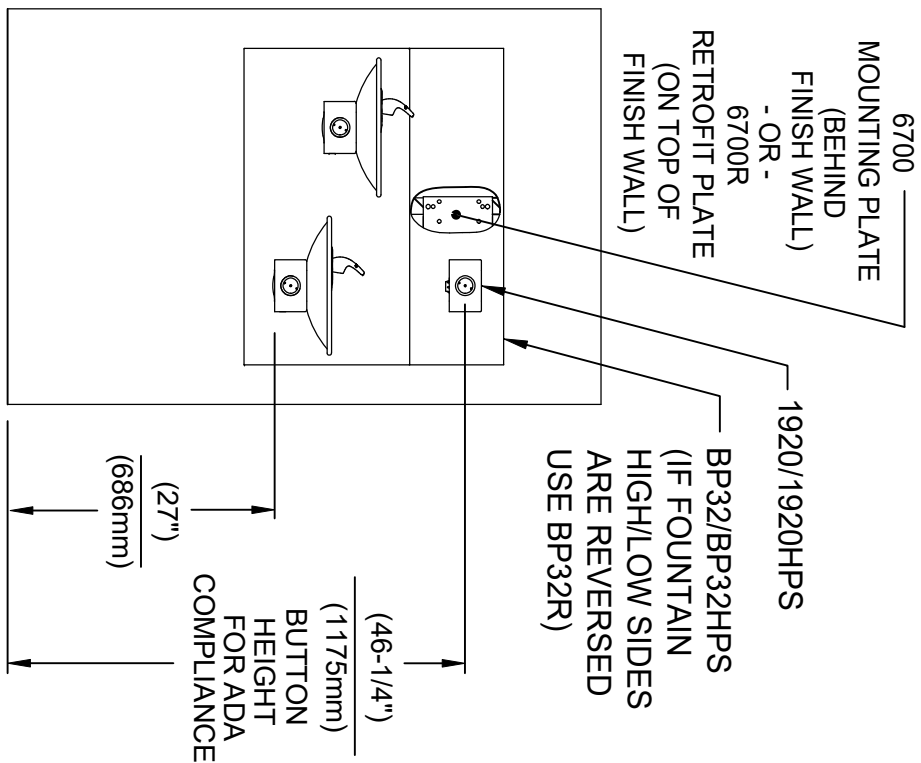

INSTALLATION ABOVE HAWS 1011 & H1011.8 SERIES

INSTALLATION ABOVE HAWS 1001 & H1001.8 SERIES

* IF YOUR FOUNTAIN IS THIS STYLE USE THESE DIMENSIONS

1. SEE SEPARATE INSTALLATION DRAWINGS FOR MOUNTING PLATES AND BACK PANELS (SHOWN FOR REFERENCE - NOT SUPPLIED).

2. WHEN INSTALLING THIS UNIT, LOCAL, STATE OR FEDERAL CODES SHOULD BE ADHERED TO FOR INSTALLATION LOCATIONS, WASTE & SUPPLY REQUIREMENTS OTHER THAN SHOWN.

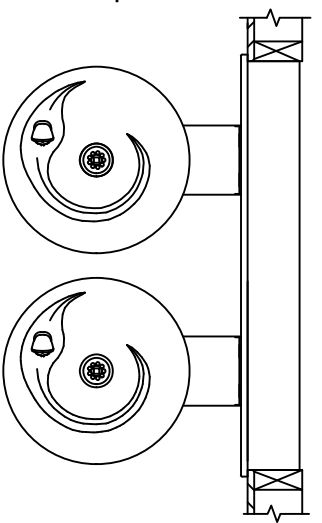

		Since 1906	
1455 KLEPPE LANE SPARKS, NEVADA 89431 (775) 359-4712 FAX (775) 359-7424 E-MAIL: HAWS@HAWSCO.COM WEBSITE: WWW.HAWSCO.COM		MODEL(S) 1920/1920HPS/1920W	
ECN NO. REVISED PER BY: JG	DATE: 11/26/24	SCALE: NA	DRAWING TYPE: INSTALLATION
DRAWN: DATE: 7/15/24	CHKD: JG	SIZE: A	SHEET 3 OF 9
APPROVED: RH	DATE: 11/26/24		
PART NUMBER: 0510000490.D	REVISION: 13		

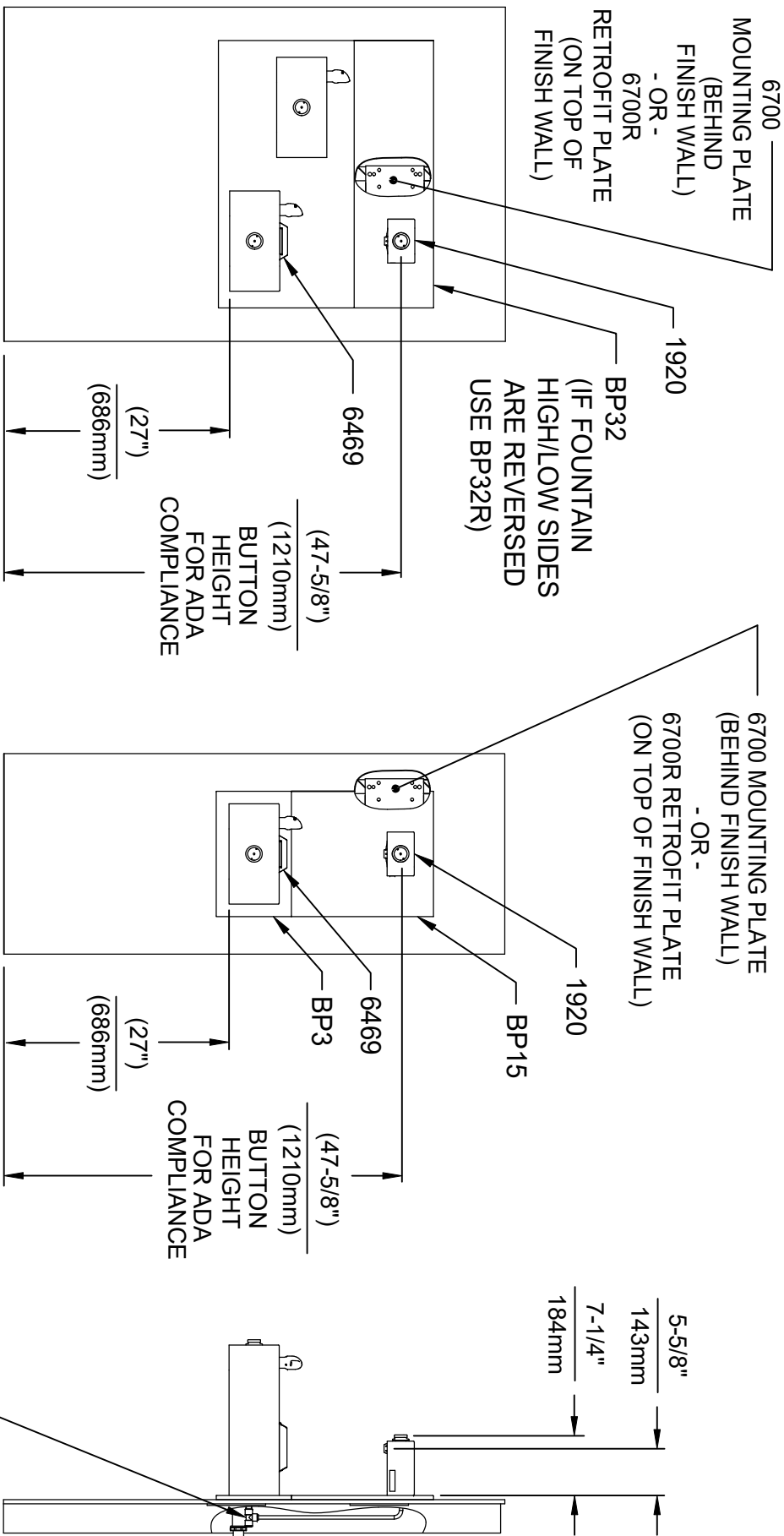

INSTALLATION ABOVE HAWS 1119 & H1119.8 SERIES

**INSTALLATION ABOVE HAWS 1109 & H1109.8 SERIES
SEE SHEET 8 FOR INSTALLATION AT CHILD HEIGHT**

* IF YOUR FOUNTAIN IS THIS STYLE USE THESE DIMENSIONS

1. SEE SEPARATE INSTALLATION DRAWINGS FOR MOUNTING PLATES AND BACK PANELS (SHOWN FOR REFERENCE - NOT SUPPLIED).
2. WHEN INSTALLING THIS UNIT, LOCAL, STATE OR FEDERAL CODES SHOULD BE ADHERED TO FOR INSTALLATION LOCATIONS, WASTE & SUPPLY REQUIREMENTS OTHER THAN SHOWN.

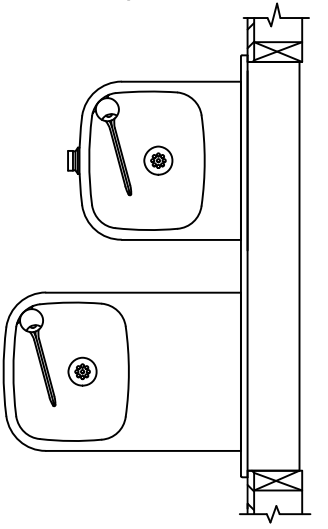

3/8" O.D. SUPPLY TUBING AND 3/8" O.D. PUSH-IN TEE SUPPLIED. (CONNECT TO FOUNTAIN SUPPLY LINE)

Haws
Since 1906

1455 KLEPPE LANE
SPARKS, NEVADA 89431
(775) 359-4712 FAX (775) 359-7424
E-MAIL: HAWS@HAWS.CO.COM
WEBSITE: WWW.HAWS.CO.COM

ECN NO. REVISED PER BY:	MODEL(S)	SCALE:	DATE:	SIZE:	SHEET:
3041		NA	11/29/24	A	4 OF 9
DRAWN DATE:	CHKD:	DATE:	DATE:	DATE:	DATE:
10/15/23	JG	10/15/23	10/15/23	10/15/23	10/15/23
APPROVED:	DATE:	SCALE:	DATE:	DATE:	DATE:
RH	11/29/24	NA	11/29/24	11/29/24	11/29/24

1920/1920HPS/1920W

PART NUMBER: 0510000490.D
REVISION: 13

6700 MOUNTING PLATE
(BEHIND FINISH WALL)
- OR -
6700R RETROFIT PLATE
(ON TOP OF FINISH WALL)

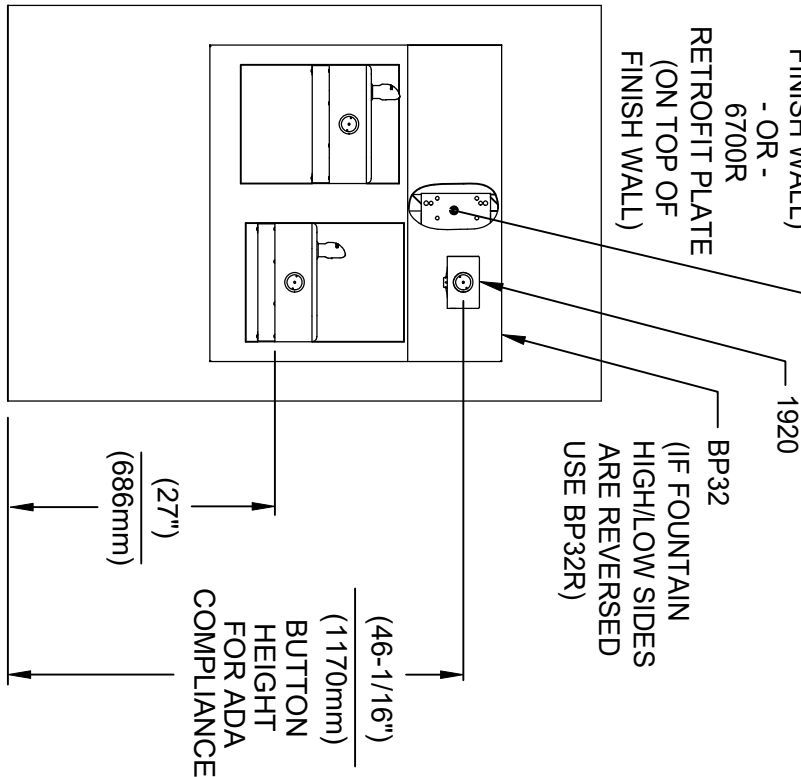

INSTALLATION ABOVE HAWS 1117L & H1117.8 SERIES

* IF YOUR FOUNTAIN IS THIS STYLE USE THESE DIMENSIONS

1. SEE SEPARATE INSTALLATION DRAWINGS FOR MOUNTING PLATES AND BACK PANELS (SHOWN FOR REFERENCE - NOT SUPPLIED).
2. WHEN INSTALLING THIS UNIT, LOCAL, STATE OR FEDERAL CODES SHOULD BE ADHERED TO FOR INSTALLATION LOCATIONS, WASTE & SUPPLY REQUIREMENTS OTHER THAN SHOWN.

6700 MOUNTING PLATE
(BEHIND FINISH WALL)
- OR -
6700R RETROFIT PLATE
(ON TOP OF FINISH WALL)

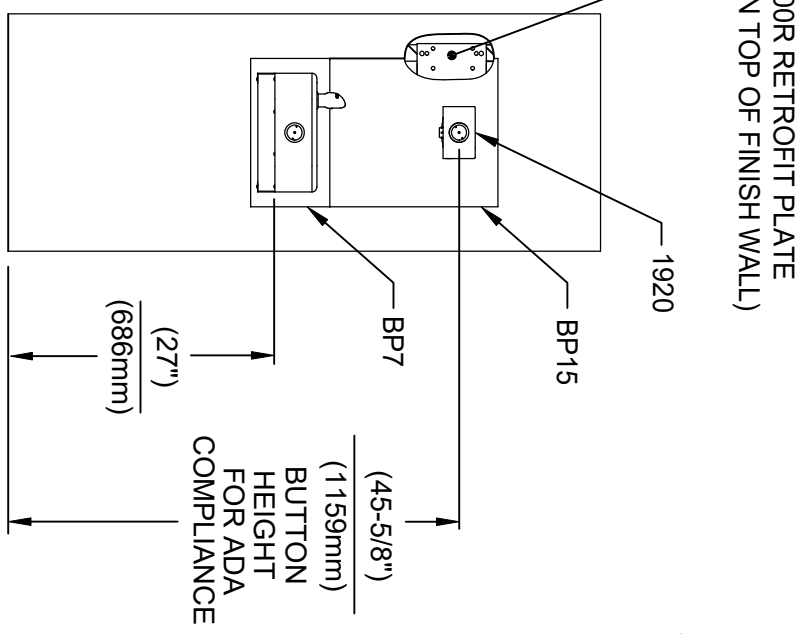

INSTALLATION ABOVE HAWS 1107L & H1107.8 SERIES

SEE SHEET 8 FOR INSTALLATION AT CHILD HEIGHT

3/8" O.D. SUPPLY TUBING AND 3/8" O.D. PUSH-IN TEE SUPPLIED. (CONNECT TO FOUNTAIN SUPPLY LINE)

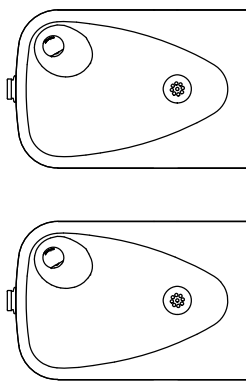
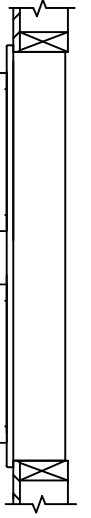
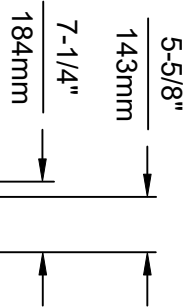

EDN NO. REVISED PER BY:	MODEL(S)	1455 KLEPPE LANE
SOFT JIG		SPARKS, NEVADA 89431
DRAWN DATE: CHG: JIG		(775) 359-4712 FAX (775) 359-7424
APPROVED: DATE: JIG		E-MAIL: HAWS@HAWS.CO.COM
RH	SCALE: NA	WEBSITE: WWW.HAWS.CO.COM
	DRAWING TYPE:	
	INSTALLATION:	
	SIZE: A	
	SHEET 5 OF 9	
	PART NUMBER	0510000490.D
	REVISION	13

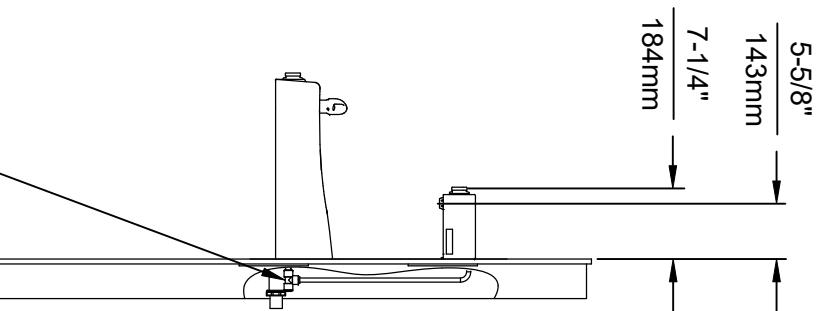
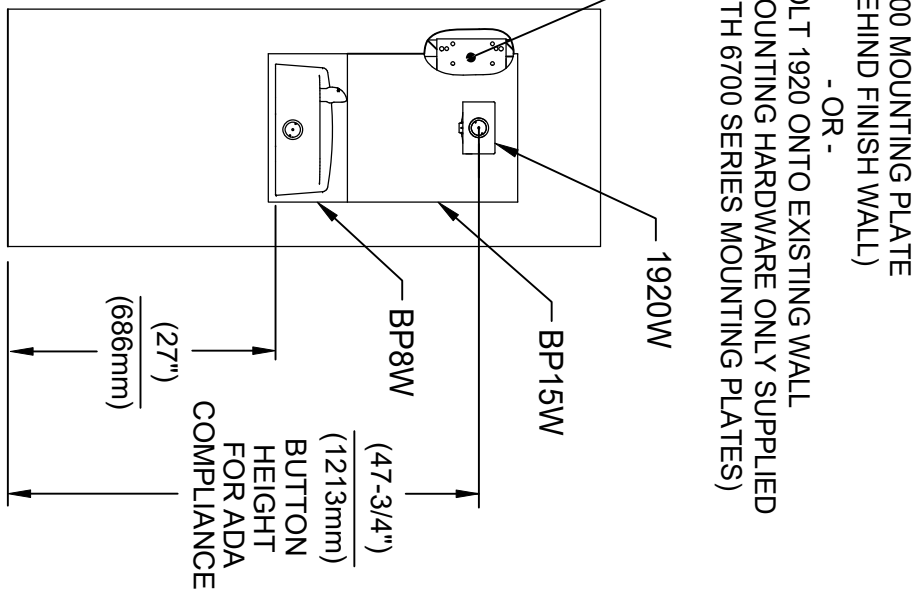
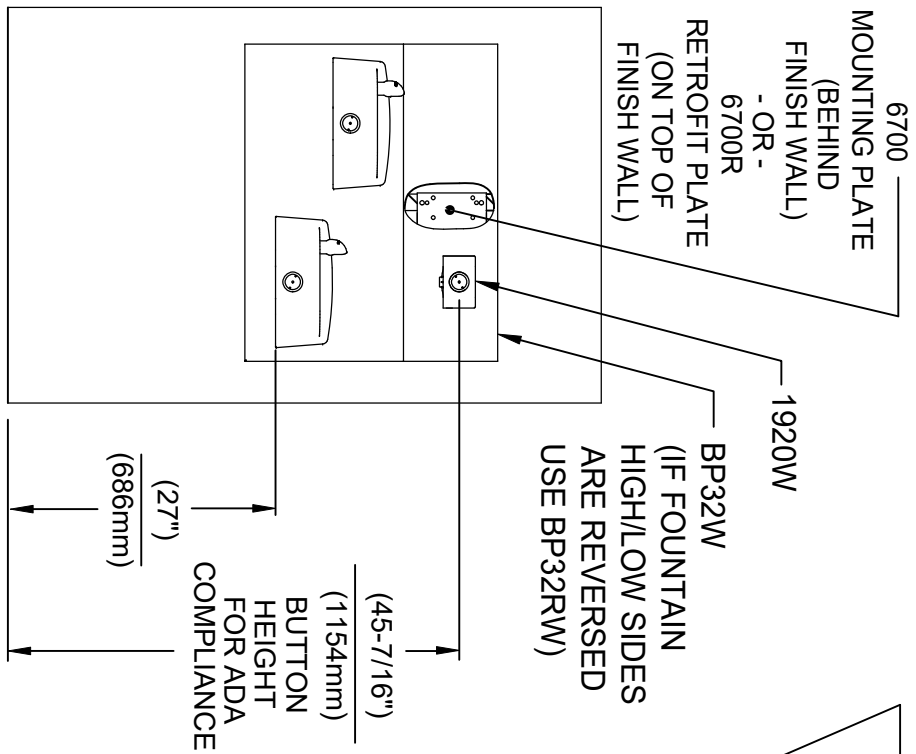

INSTALLATION ABOVE HAWS 1501

**INSTALLATION ABOVE HAWS 1311
SEE SHEET 8 FOR INSTALLATION AT CHILD HEIGHT**

* IF YOUR FOUNTAIN IS THIS STYLE USE THESE DIMENSIONS

1. SEE SEPARATE INSTALLATION DRAWINGS FOR MOUNTING PLATES AND BACK PANELS (SHOWN FOR REFERENCE - NOT SUPPLIED).
2. WHEN INSTALLING THIS UNIT, LOCAL, STATE OR FEDERAL CODES SHOULD BE ADHERED TO FOR INSTALLATION LOCATIONS, WASTE & SUPPLY REQUIREMENTS OTHER THAN SHOWN.

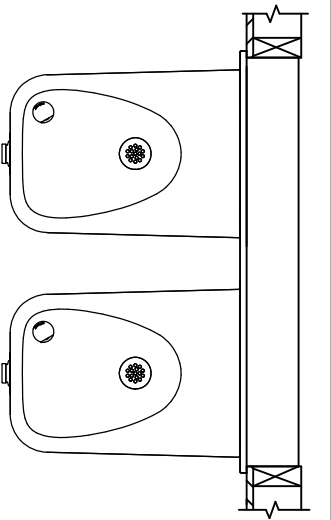

3/8" O.D. SUPPLY TUBING AND 3/8" O.D. PUSH-IN TEE SUPPLIED. (CONNECT TO FOUNTAIN SUPPLY LINE)

Haws
Since 1906

1455 KLEPPE LANE
SPARKS, NEVADA 89431
(775) 359-4712 FAX (775) 359-7424
E-MAIL: HAWS@HAWS.CO.COM
WEBSITE: WWW.HAWS.CO.COM

EQ. NO.	REVISED PER BY:	MODEL(S)
5031	EQ. 6131	
DRAWN	DATE	CHG.
10/25/07	10/25/07	JG
APPROVED:	DATE	
RH	11/26/24	
SCALE:	N/A	DRAWING TYPE:
		INSTALLATION
SIZE:	A	SHEET:
		6 OF 9
PART NUMBER	0510000490.D	REVISION
		13

6700 MOUNTING PLATE
(BEHIND FINISH WALL)
- OR -
BOLT 1920 ONTO EXISTING WALL
(MOUNTING HARDWARE ONLY SUPPLIED
WITH 6700 SERIES MOUNTING PLATES)

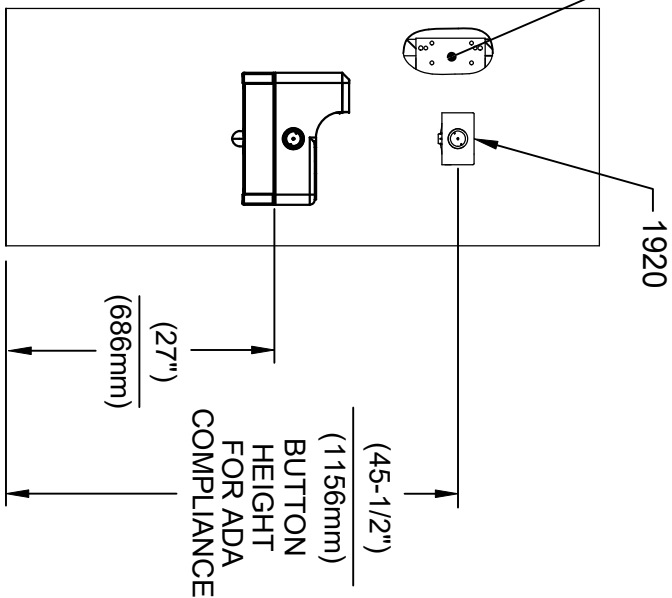

INSTALLATION ABOVE HAWS 1047

* IF YOUR FOUNTAIN IS THIS STYLE USE THESE DIMENSIONS

1. SEE SEPARATE INSTALLATION DRAWINGS FOR MOUNTING PLATES AND BACK PANELS (SHOWN FOR REFERENCE - NOT SUPPLIED).
2. WHEN INSTALLING THIS UNIT, LOCAL, STATE OR FEDERAL CODES SHOULD BE ADHERED TO FOR INSTALLATION LOCATIONS, WASTE & SUPPLY REQUIREMENTS OTHER THAN SHOWN.

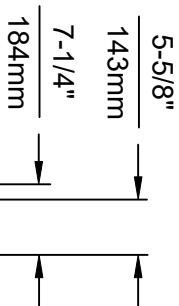
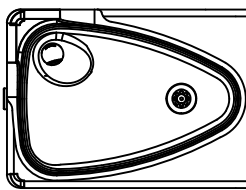

3/8" O.D. SUPPLY TUBING AND 3/8" O.D. PUSH-IN TEE SUPPLIED. (CONNECT TO FOUNTAIN SUPPLY LINE)

		Since 1906	
1455 KLEPPE LANE SPARKS, NEVADA 89431 (775) 359-4712 FAX (775) 359-7424 E-MAIL: HAWS@HAWSCO.COM WEBSITE: WWW.HAWSCO.COM		MODEL(S) 1920/1920HPS/1920W	
EQUIP. NO. 3220	REVISED PER BY J.G.	DATE 11/28/24	SCALE N/A
DRAWN BY RH	DATE 11/28/24	DRAWING TYPE INSTALLATION	SIZE A
PART NUMBER 0510000490.D		SHEET 7 OF 9	

6700 MOUNTING PLATE
(BEHIND FINISH WALL)
-OR-
6700R RETROFIT PLATE
(ON TOP OF FINISH WALL)

* MODELS 1920 (BOTTLE FILLER),
BP15, BP6 (BACK PANELS) AND
6468 (WASTE DRIP TRAY) ARE
ALL AVAILABLE TOGETHER AS
MODEL 1922.

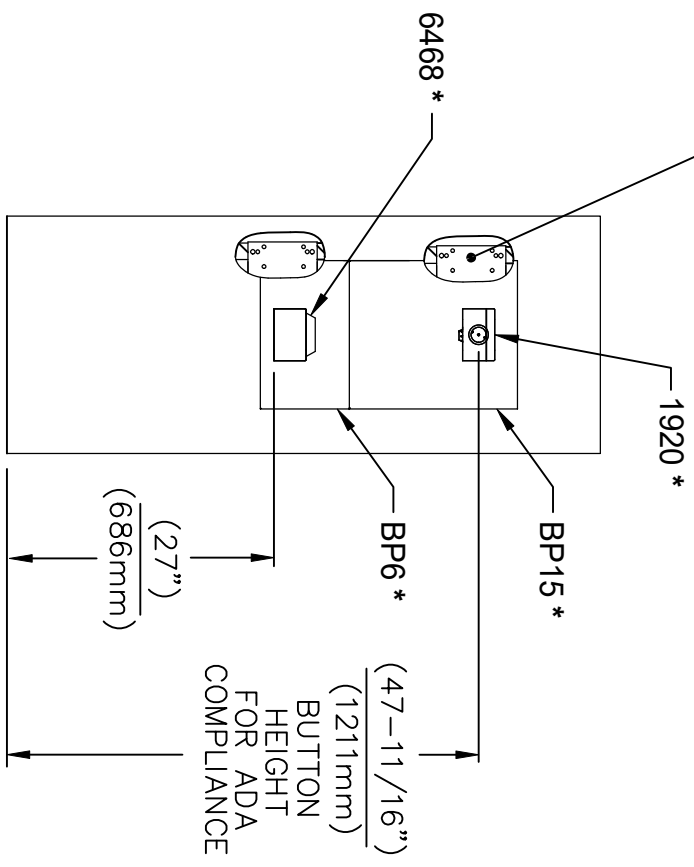

INSTALLATION ABOVE 6468

1. SEE SEPARATE INSTALLATION DRAWINGS FOR MOUNTING PLATE, WASTE DRIP TRAY AND BACK PANELS (SHOWN FOR REFERENCE - NOT SUPPLIED).
2. WHEN INSTALLING THIS UNIT, LOCAL, STATE OR FEDERAL CODES SHOULD BE ADHERED TO FOR INSTALLATION LOCATIONS, WASTE & SUPPLY REQUIREMENTS OTHER THAN SHOWN.

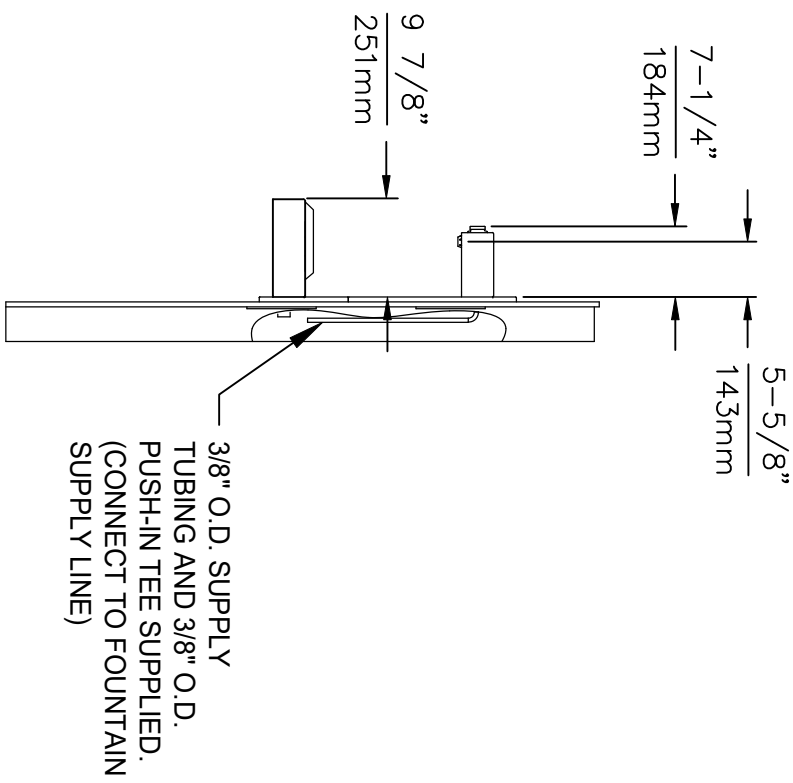

 <p>Haws Since 1906</p>		<p>1455 KLEPPE LANE SPARKS, NEVADA 89431 (775) 359-4712 FAX (775) 359-7424 E-MAIL: HAWS@HAWSCO.COM WEBSITE: WWW.HAWSCO.COM</p>	
<p>EQD NO. REVISED PER BY: J.G. DRAWN DATE: 11/28/24 APPROVED: RH DATE: 11/28/24</p>	<p>MODEL(S) 1920/1920HPS/1920W</p>	<p>SCALE: N/A DRAWING TYPE: INSTALLATION</p>	<p>PART NUMBER: 0510000490.D REVISION: 13</p>

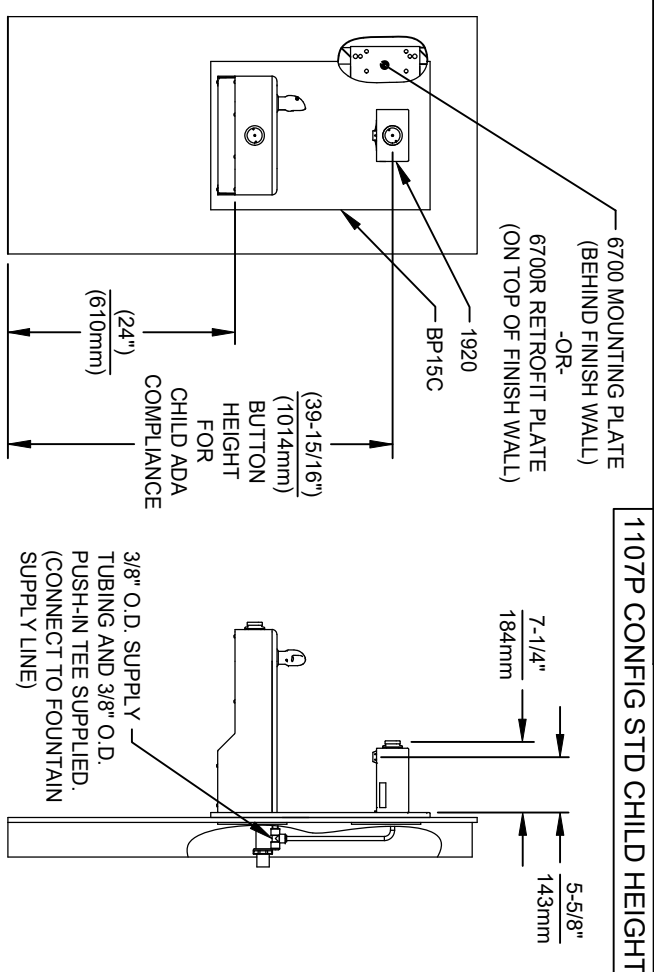

1107P CONFIG STD CHILD HEIGHT

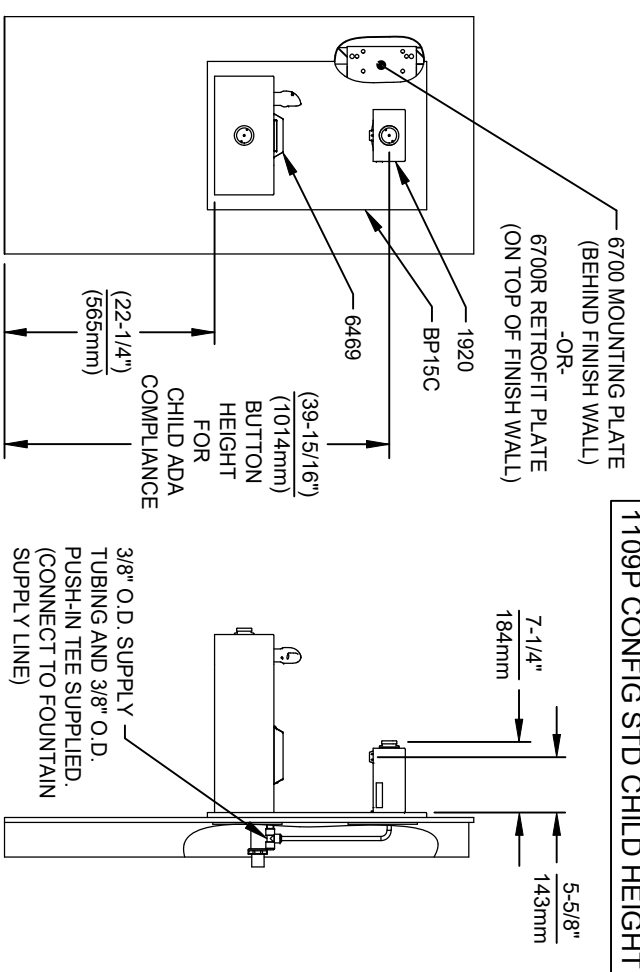

1109P CONFIG STD CHILD HEIGHT

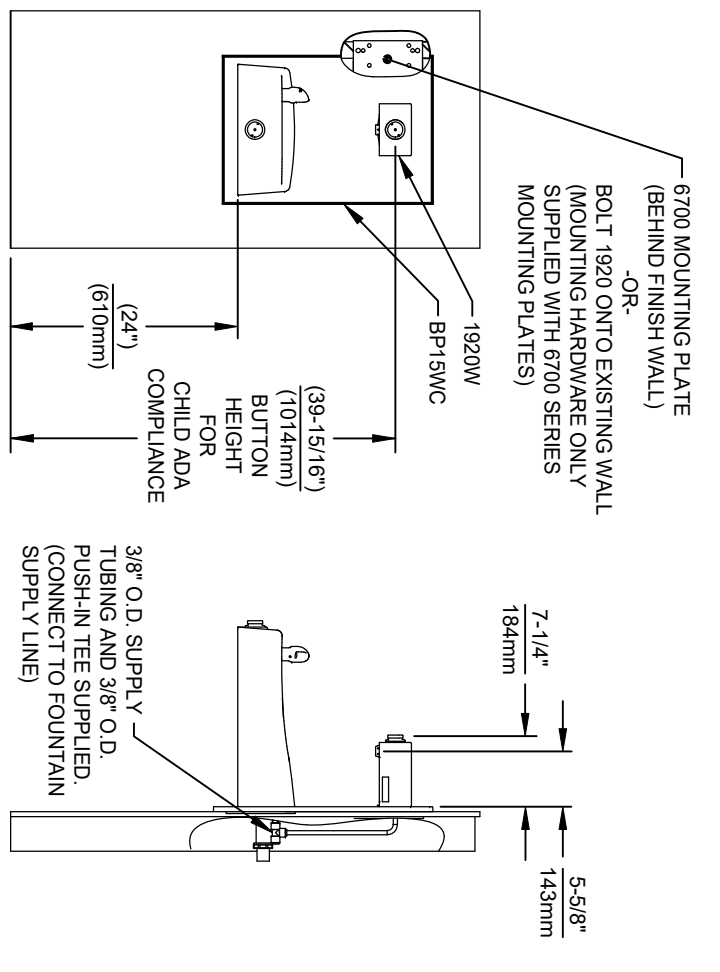

1311P CONFIG STD CHILD HEIGHT

INSTALLATION FOR 1311P CONFIG STD CHILD HEIGHT

NOTES:

- HEIGHT DIMENSIONS SHOWN ARE FOR CHILD ADA APPLICATIONS:
- BOTTLE FILLER HEIGHT AT 40" MAX.
- DRINKING FOUNTAIN BUBBLER HEIGHT AT 30" MAX.
(SEE SHEETS 3, 4 & 5 FOR ADULT ADA HEIGHT DIMENSIONS)
- SEE SEPARATE 6700 DRAWINGS FOR MOUNTING PLATES AND BACK PANELS (SHOWN FOR REFERENCE - SOLD SEPARATELY OR PART OF A BUNDLED PRODUCT).
- WHEN INSTALLING THIS UNIT, LOCAL, STATE OR FEDERAL CODES SHOULD BE ADHERED TO FOR INSTALLATION LOCATIONS, WASTE & SUPPLY REQUIREMENTS OTHER THAN SHOWN.

Haws
Since 1906

1455 KLEPPE LANE
SPARKS, NEVADA 89431
(775) 359-4712 FAX (775) 359-7424
E-MAIL: HAWS@HAWS.CO.COM
WEBSITE: WWW.HAWS.CO.COM

EQ.ND. REVISED PER BY: MODEL(S)
350V EQ.N. 6131 J.G. 1920/1920HPS/1920W
DRAWN DATE: CHG. J.G.
APPROVED: DATE: 11/29/24 SCALE: N/A DRAWING TYPE: INSTALLATION SIZE: A SHEET 9 OF 9

PART NUMBER: 0510000490.D
REVISION: 13