



Haws®

model 1107L

ADA Vandal-Resistant Wall Mount Drinking Fountain

FEATURES & BENEFITS

CONSTRUCTION

One-piece drinking fountain with low-profile design made of 14 gauge Type 304 stainless steel with 1/4" (.6 cm) thick stainless back plate welded in, and vandal-resistant stainless bottom plate. Satin finish resists stains and corrosion.

ACCESS

Low profile designed bowl and integral trap allow for knee clearance for adult or child ADA access (when installed at appropriate heights).

BUBBLER HEAD

Polished chrome-plated brass bubbler head with integral 11/16" dia. basin shank and stainless anti-rotation roll pin for vandal resistance strength. Shielded, angled stream opening provides a steady, sanitary source of drinking water at .45 gpm.

DRINKING FOUNTAIN VALVE

The push-button activated valve offers the only all stainless steel valve body that is machined out of solid bar stock, is fully serviceable through the front of the push button assembly offering access to the water control cartridge and integral water supply strainer, and with front access to the water stream height adjustment for easy maintenance without having to remove the valve. Operating pressure range of 30 to 90 psi (2.1 to 6.2 bar).

INTEGRATED TRAP

All cast brass 1-1/4" NPT adjustable trap completely concealed inside bottom plate for easy installation and access.



OPTIONS

- Bottle Filler: Model 1920 stand-alone bottle filling station, or mounted above Haws 1001, 1011, 1107L, 1109, 1117L, and 1119 series drinking fountain models.
- Bottle Filler Stand: Model BTL1107, add-on stainless steel stand to place bottle on when 1920 bottle filler is used.
- Mounting Plate: Model 6700 universal mounting plate for most wall mounted fountains.
- Support Frame: Model 6800 In-wall floor mounted fixture support legs, welded steel 4-bolt floor flanges, and supplied with 'U' bolts and hardware.

For more information, visit www.hawsc.com or call (888) 640-4297.

SPECIFICATIONS

Model 1107L wall mounted vandal-resistant, barrier-free drinking fountain shall include a 14 gauge Type 304 Stainless Steel satin finish basin with integral 1/4" (.6 cm) thick stainless steel back plate. Push-button operated stainless steel valve with front-accessible cartridge, in-line strainer and flow adjustment provides 100% lead free waterways, polished chrome-plated brass vandal-resistant bubbler head, polished chrome-plated brass vandal-resistant waste strainer, vandal-resistant stainless bottom plate, and a 1-1/4" NPT concealed all cast-brass trap. Unit can be mounted to meet ADA or Child ADA specifications.

APPLICATIONS

Perfect for either public or private indoor/outdoor settings, the 1107L is a great fit in areas where aesthetics are important to the overall appeal of the architecture. Beautiful satin finish helps to maintain the fountains overall appeal. Specifically, this type of wall mounted drinking fountain may be placed in settings such as: schools and other locations in and around office buildings where the temperature remains above freezing. Model meets all current Federal Regulations for the disabled including those in the Americans with Disabilities Act. Haws manufactures drinking fountains, faucets and electric water coolers to be lead-free by all known definitions including NSF/ANSI/CAN 61-Section 9, NSF/ANSI/CAN 372, California Proposition 65, and the Federal Safe Drinking Water Act. Product is compliant to California Health and Safety Code 116875 (AB 1953-2006), and NSF/ANSI/CAN 61: Q ≤ 1.



NOTES:

1. HOLD ROUGH-IN DIMENSIONS ± 1/4" (6.4mm)
2. WHEN INSTALLING THIS UNIT, LOCAL, STATE OR FEDERAL CODES SHOULD BE ADHERED TO. FOR INSTALLATION HEIGHTS OTHER THAN SHOWN, DIMENSIONS MARKED (*) MUST BE ADJUSTED ACCORDINGLY.

3 REFER TO 5874 SERIES OPERATION AND MAINTENANCE MANUAL FOR PUSH BUTTON AND VALVE INSTALLATION AND MAINTENANCE INSTRUCTIONS.

4 ROUGH IN DIMENSIONS FOR FOUNTAIN HEIGHTS:

CHILD WHEELCHAIR HEIGHT: SEE SHT 2 FIG 1

- WASTE: 26-1/4" (667mm)
- SUPPLY: 26-1/8" (664mm)
- MOUNTING HOLE: 24-13/16" (630mm)
- MOUNTING PLATE: 23-3/16" (589mm)
- FOUNTAIN: 24" (610mm)
- BUBBLER: 29-7/8" (756mm)

ADULT WHEELCHAIR HEIGHT: SEE SHT 2 FIG 2

- WASTE: 29-1/4" (743mm)
- SUPPLY: 29-1/8" (740mm)
- MOUNTING HOLE: 27-13/16" (706mm)
- MOUNTING PLATE: 26-3/16" (665mm)
- FOUNTAIN: 27" (686mm)
- BUBBLER: 32-7/8" (832mm)

STANDING ADULT HEIGHT: SEE SHT 2 FIG 3

- WASTE: 34-3/4" (883mm)
- SUPPLY: 34-5/8" (879mm)
- MOUNTING HOLE: 33-5/16" (846mm)
- MOUNTING PLATE: 31-11/16" (805mm)
- FOUNTAIN: 32-1/5" (826mm)
- BUBBLER: 38-3/8" (972mm)

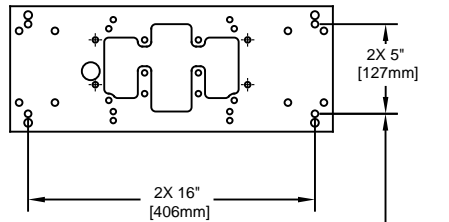
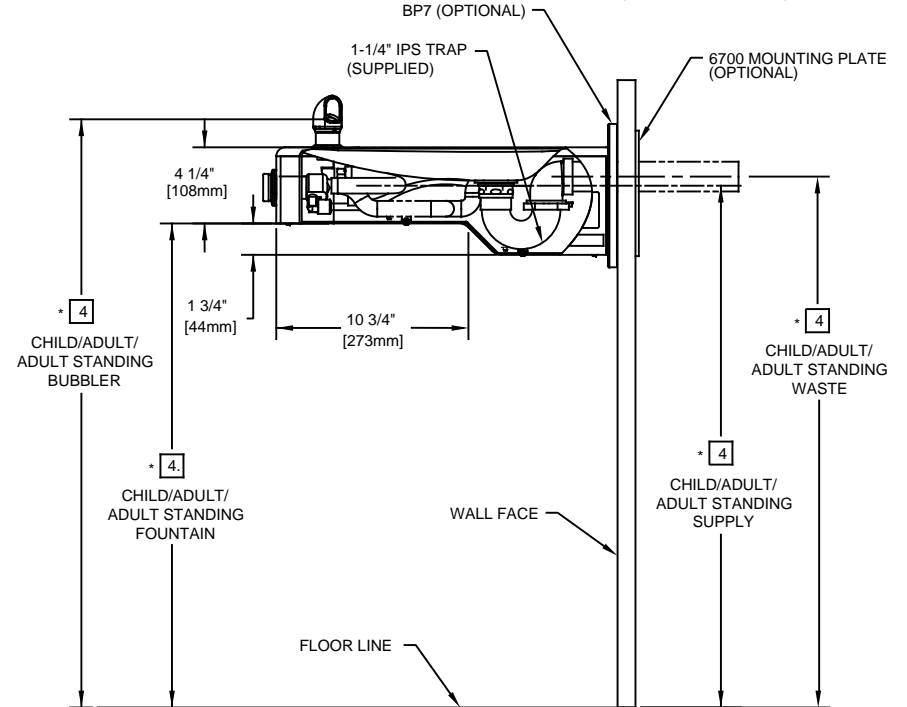
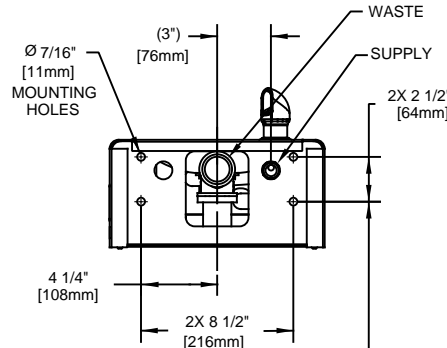
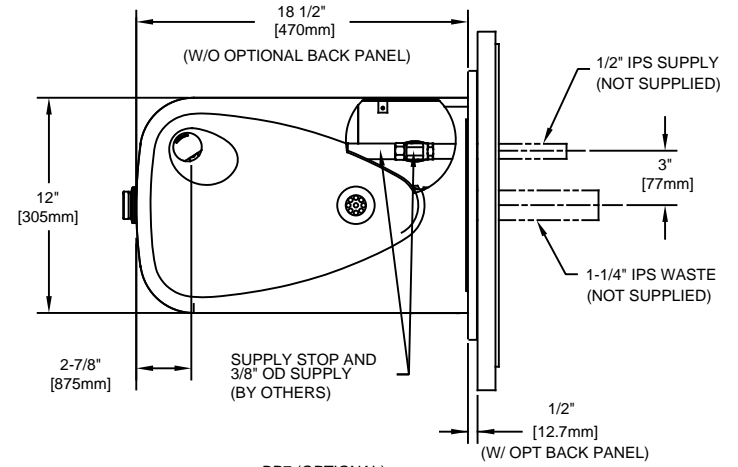
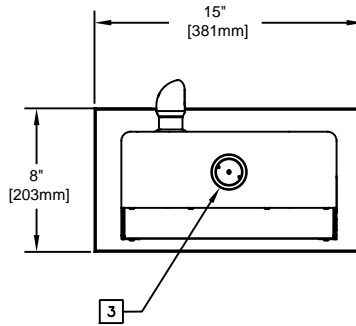

CHILD/ADULT/ADULT STANDING MOUNTING PLATE

MOUNTING DETAIL
BACK VIEW

MOUNTING PLATE
(OPTIONAL, HAWS 6700)

1455 KLEPPE LANE
SPARKS, NEVADA 89431
(775) 359-4712 FAX (775) 359-7424
E-MAIL: HAWS@HAWSCO.COM
WEBSITE: WWW.HAWSCO.COM

ECN NO.	REVISED PER	BY:	MODEL(S)	PART NUMBER
	ECN: 5215	JP		0002080232.D
DRAWN:	DATE:	CHKD.:	1107L	REVISION
C.FENNER	10/25/06	GC		15
APPROVED:	DATE:	SCALE:	DRAWING TYPE:	SHEET 1 OF 1
FV	11/22/17	1:1	INSTALLATION	