

FEATURES & BENEFITS

MOUNTING

Heavy duty 3/16" (.47 cm) steel pre-drilled and threaded on-wall mounting plate along with all-thread studs and hardware.

OPTIONS

For more information, visit www.hawsco.com or call (888) 640-4297.

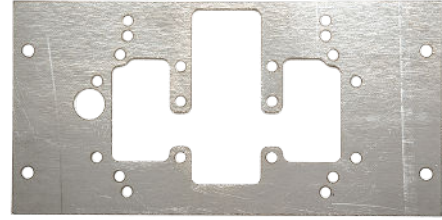

SPECIFICATIONS

Model 6700R on-wall 3/16" thick steel mounting plate is stronger and thicker than any other plate in the industry. It is designed to aid the installation for and support of the 1920 series bottle filler on an existing wall. Plate is to be mounted on the surface of a finished wall and is concealed behind optional (or supplied) back panel. Measurements are 14" W x 7" H x 3/16" (35.6 x 17.8 x .47 cm). For new construction installs, see model 6700.

APPLICATIONS

MARK THESE HOLE LOCATIONS

STEP 1

PLACE BACK PANEL ON TOP OF INSTALLED (EXISTING) DRINKING FOUNTAIN (IF APPLICABLE). MARK THE HOLE LOCATIONS ONTO THE WALL (SEE NOTE 1 BELOW).

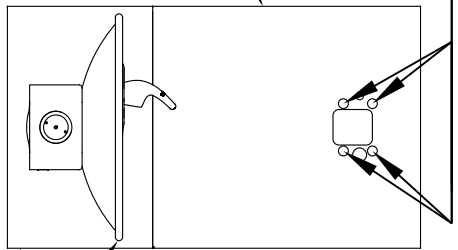

BP15/BP15HPS/BP15W BACK PANEL (SINGLE) SHOWN FOR REFERENCE ONLY (NOT SUPPLIED). BP15C/BP15WC ARE ONE-PIECE BACK PANELS (NOT SHOWN AND NOT SUPPLIED) USED FOR MOUNTING BOTH BOTTLE FILLER AND DRINKING FOUNTAIN ON SAME PANEL AND REQUIRE TWO 6700R MOUNTING PLATES.

STEP 2

LINE UP THE 6700R MOUNTING PLATE(S) OVER THE MARKED HOLES. ATTACH THE PLATE(S) TO THE WALL USING APPROPRIATE ANCHORS.

DRINKING FOUNTAIN & BACK PANEL SHOWN FOR REFERENCE ONLY (NOT SUPPLIED)

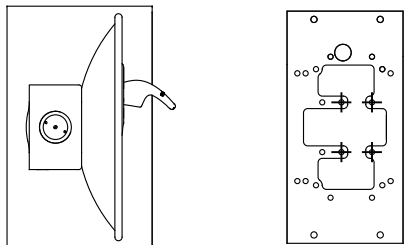

STEP 3

INSTALL THE BOLTS IN THE MOUNTING PLATE(S) BY SECURING WITH NUTS AND WASHERS. RECESS FOR THE REAR NUTS MAY BE REQUIRED.

INSTALLATION STEPS SHOWN ARE FOR SINGLE BOTTLE FILLER PANEL BUT CAN BE APPLIED TO ONE-PIECE PANEL (COMBINATION BOTTLE FILLER AND DRINKING FOUNTAIN) USED FOR CHILD HEIGHT APPLICATIONS.

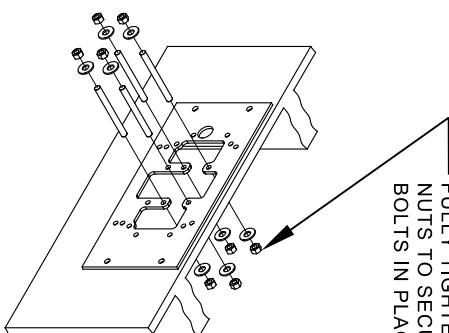

FULLY TIGHTEN NUTS TO SECURE BOLTS IN PLACE.

MODEL 6700R

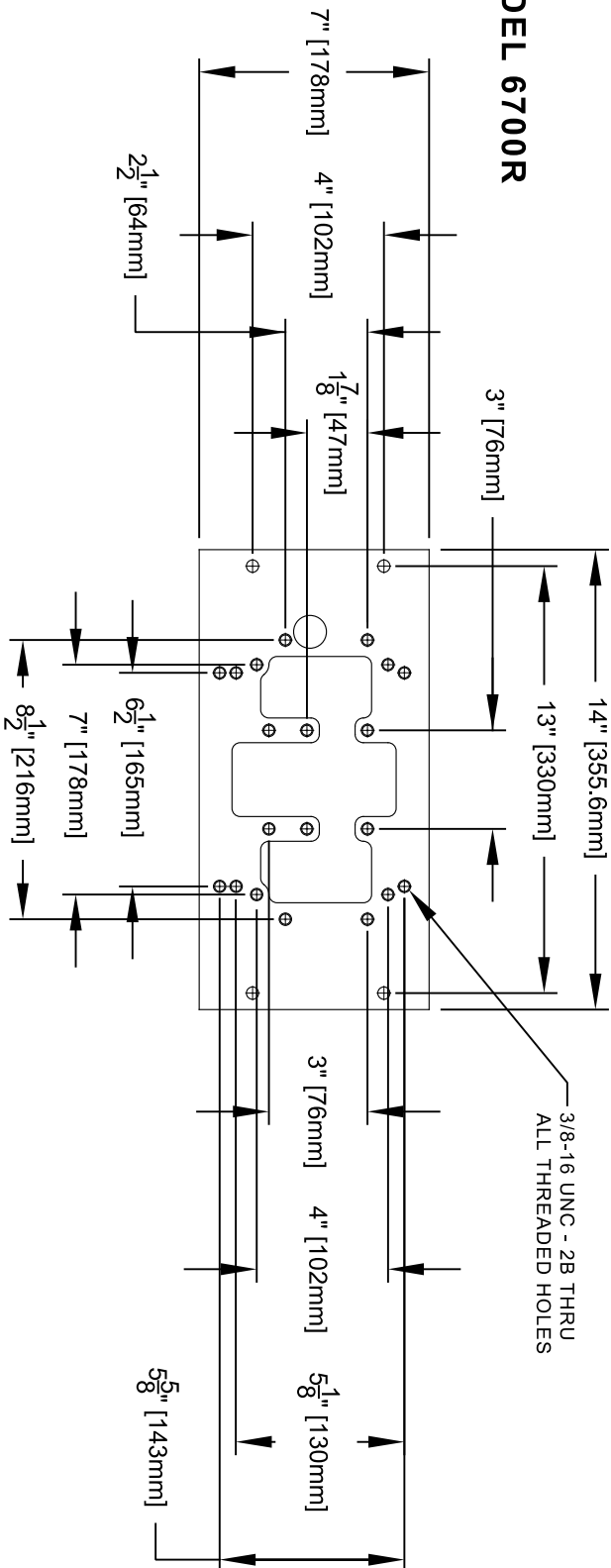

NOTES:

1. WHEN INSTALLING THIS UNIT, LOCAL, STATE OR FEDERAL CODES SHOULD BE ADHERED TO.

2. FOR CONCRETE/MASONRY WALLS, DO NOT INSTALL THE MOUNTING PLATE ON THE SAME SIDE OF WALL AS FOUNTAIN/BOTTLE FILLER. CALL TECHNICAL SUPPORT IF THERE ARE ANY QUESTIONS AS TO HOW TO OBTAIN A PROPER ANCHOR IN CONCRETE/MASONRY WALL. 1-800-766-5612

 <p>Haws Since 1906</p>		1459 KLEPPE LANE SPARKS, NEVADA 89431 (775) 399-4712 FAX (775) 399-7424 E-MAIL: HAWS@HAWSCO.COM WEBSITE: WWW.HAWSCO.COM	
		MODEL(S) 6700R	
ECN NO. REVISED PER BY: 5081 ECN 6005 FV	ECN NO. REVISED PER BY: 5081 ECN 6005 FV	DATE: 06/27/16 CHK'D: KM	DATE: 02/26/24 CHK'D: KM
DRAWN: MJ APPROVED: FV	SCALE: 1:1 DRAWING TYPE: INSTALLATION	SIZE: A SHEET: 1 OF 1	PART NUMBER: 0510000492 REVISION: 4