



model 8317LTEXP
Area Light

FEATURES & BENEFITS

OPTIONS

For more information, visit www.hawsc.com or call (888) 640-4297.



SPECIFICATIONS

Model 8317LTEXP is a white area light for continuous illumination of the 8317CTFP series showers. Class 1, Div. 1, Group C & D. Tempering Code: T4. Model is CSA electrical certified, TYPE 4; only when used with 8317CTFP.

APPLICATIONS

Model is CSA electrical certified, TYPE 4; only when used with 8317CTFP.



NOTES:

1. INSTALLER MUST USE SUFFICIENT THREAD SEALANT, SUCH AS APPLETON TLC-3, RECOMMENDED FOR USE IN HAZARDOUS LOCATIONS, TO ENSURE A WATERTIGHT SEAL ON ALL ELECTRICAL THREAD CONNECTIONS.
 2. ALL INSTALLATIONS MUST BE INSTALLED IN COMPLIANCE WITH LOCAL, STATE, AND/OR FEDERAL CODES.
 3. WARNING: WHEN INSTALLED ON ANY 8317CTFP SERIES UNIT, THE ASSEMBLY IS ONLY RATED FOR GROUPS C & D AND T4.
- (NOTES CONTINUED ON SHEET 2)

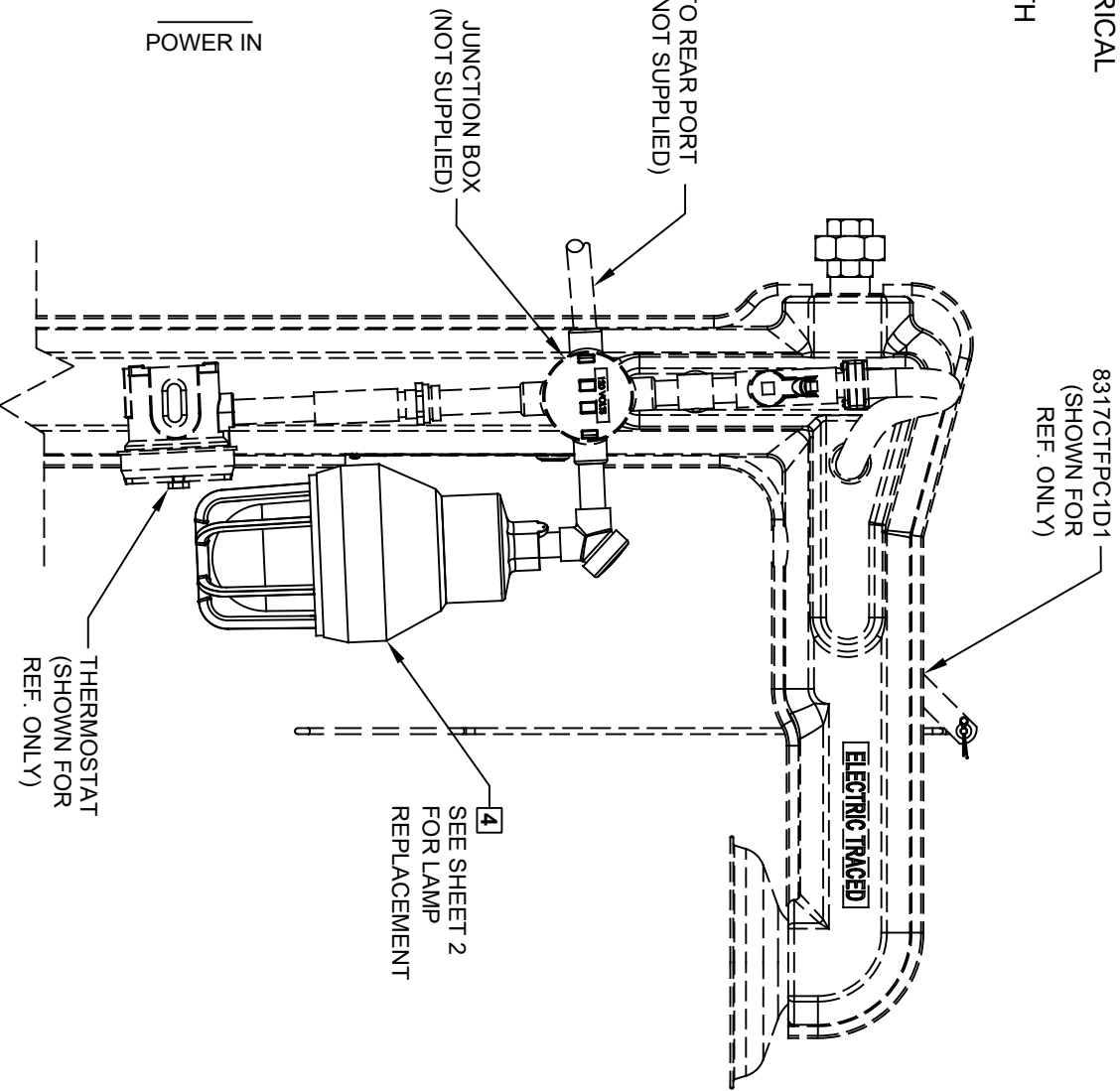
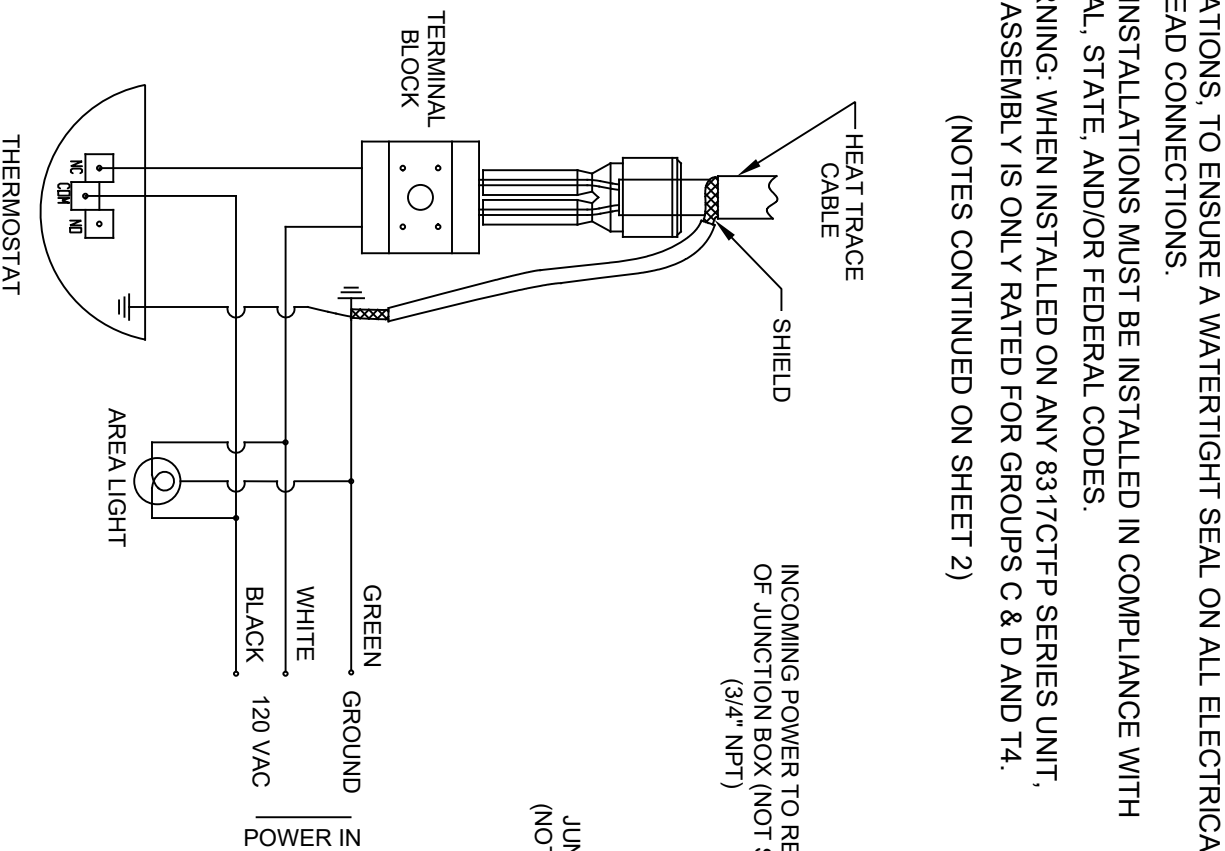

8317LTEXP WIRING DETAIL

		1459 KLEPPE LANE SPARKS, NEVADA 89431 (775) 359-4712 FAX (775) 359-7424 E-MAIL: HAWS@HAWSCO.COM WEBSITE: WWW.HAWSCO.COM	
ECN NO. REVISED PER BY:	MODEL(S)	8317LTEXP	
DRAWN: HERRITT	DATE: 8/17/09	ECN: 5775	CHKD: JS
APPROVED: FV	DATE: 02/22/22	SCALE: 1:1	DRAWING TYPE: INSTALLATION
PART NUMBER		0002080166	
REVISION:		14	

NOTES: (CONTINUED FROM SHEET 1)

4 LIGHT REPLACEMENT INSTRUCTIONS:

- 1) REMOVE GUARD/GLOBE ASSEMBLY:
FIRST LOOSEN SET SCREW (LOCATED ON GUARD WHERE SHOWN). NEXT, ROTATE ASSEMBLY COUNTER CLOCKWISE UNTIL GUARD IS FREE FROM PENDANT MOUNT AND LAMP IS EXPOSED.
- 2) ONLY REPLACE LAMP WITH HAWS P/N 00033200003.
WARNING - EXPLOSION HAZARD - SUBSTITUTION OF COMPONENTS MAY IMPAIR SUITABILITY FOR CLASS 1, DIVISION 1.
- 3) REPLACE GUARD/GLOBE ASSEMBLY:
ROTATE ASSEMBLY CLOCKWISE ONTO THE PENDANT MOUNT UNTIL TIGHT AND TIGHTEN SET SCREW.

SEE WARNING IN NOTE 4
(STEP 2) OF THIS SHEET
AND IN NOTE 3 ON SHEET 1

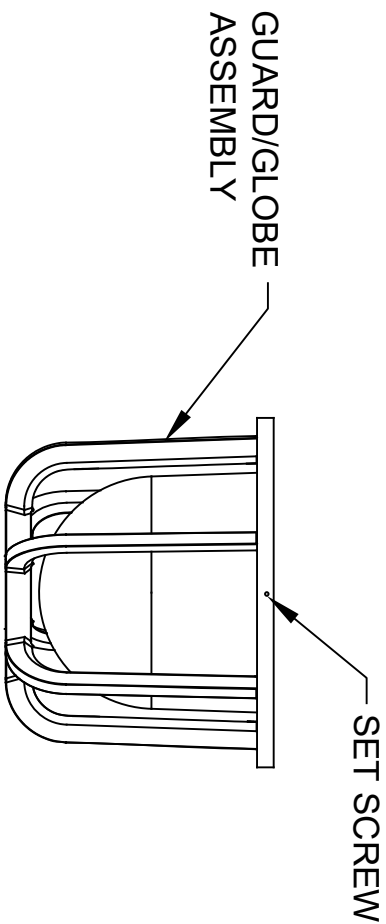
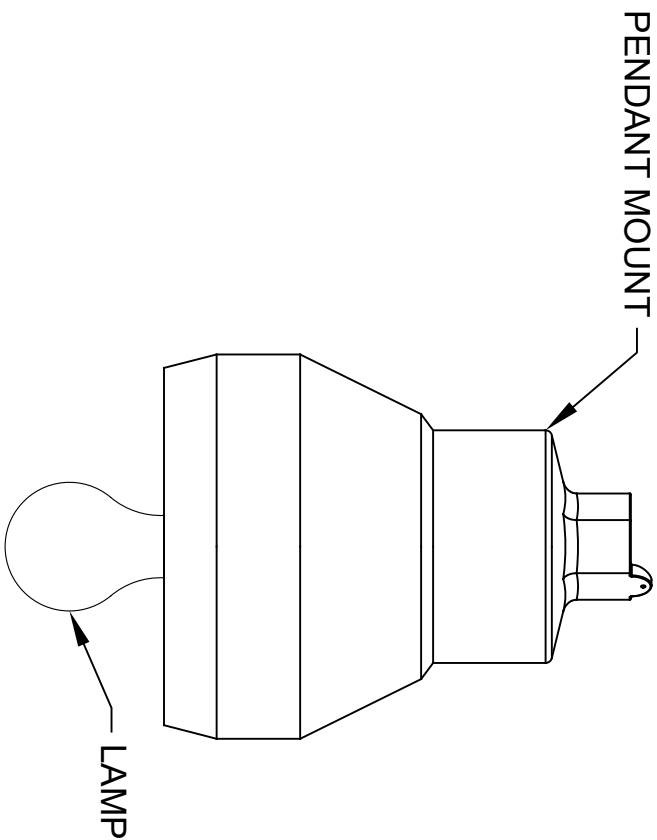

				1459 KLEPPE LANE SPARKS, NEVADA, 89431 (775) 359-4712 FAX (775) 359-7424 E-MAIL: HAWS@HAWS.CO.COM WEBSITE: WWW.HAWS.CO.COM	
ECN NO. REVISED PER BY:	MODEL(S)	8317LTEXP			
ECN: 5775	DATE: 8/17/09	CHKD: JS			
DRAWN: H. MERRITT	DATE: 02/22/22	SCALE: 1:1	DRAWING TYPE:	INSTALLATION:	SHEET 2 OF 2
APPROVED: FV	REVISION: 14	PART NUMBER 0002080166			