

GY Series

MODEL GYQ84 PEDESTAL MOUNTED BOTTLE FILLER WITH BI-LEVEL DRINKING FOUNTAIN

STANDARD FEATURES

- Adult ADA compliant
- Pushbutton and hands free sensor operated bottle filler
- Battery pack 6-AA
- Laminar flow water supply to bottle filler
- Resistant to sunlight, heat, moisture and wear
- 18 Gage, 304 stainless steel drinking Fountain bowls
- 12 Gage, heavy duty stainless steel construction with corrosion and scratch resistant finish
- Stainless steel, anti-rotation non-squirt bubbler
- 100 mesh inlet strainer
- Lead and cyst filter (Not available with FRU option)
- Access cover, heavy duty stainless steel, Vandal resistant

SUGGESTED SPECIFICATIONS

Pedestal mounted bottle filler with bi-level drinking fountain shall be Murdock model GYQ84. Construction shall be 12 gage, all stainless steel with 18 gage stainless steel fountain bowls. Pedestal shall have four mounting holes. Access covers shall be secured with vandal-resistant stainless steel screws. Bottle filler shall be activated by a 9 volt sensor or a pushbutton as standard and provide 1.0 GPM flow. Unit shall contain a 100 mesh inlet strainer, lead and cyst filter, 6-AA battery pack and laminar flow spout. Self-closing pushbuttons, needing less than 5 pounds force, shall activate internally mounted valves with adjustable stream regulators. Bubblers shall be stainless steel with non-squirt feature and operate on water pressure range of 20-105 psig. Fountain is certified to ANSI A117.1. Unit shall be certified to Public Law 111-380 (NO-LEAD) and NSF/ANSI/CAN 61. Fixture meets ADA and ADA Standing Person, requirements when mounted appropriately.

Option Notes:

¹ See separate option sheet

² This option is not available freeze-resistant.

Complies with the following standards:



Federal Public Law 111-380 (No Lead)



Model GYQ85-PF Shown

MODEL:

(Must Specify)

- GYQ84 Satin Stainless Finish
- GYQ85 Green Powder-Coated (Shown)
- GYQ86 Red Powder-Coated
- GYQ87 Blue Powder-Coated

OPTIONAL ACCESSORIES

(additional costs may be incurred)

- CH30 Child height, 30" Bubbler Height (Lower Arm)
- CV Cartridge valve on fountains (Not available with freeze-resistant valve)
- FRU3 Underground freeze-resistant, 3 valves¹ (Less filter and sensor)
- FRU4 Underground freeze-resistant, 4 valves¹ (Less filter and sensor)
- HB1 Hose bibb, compression, with hose threaded outlet/VB^{1 2}
- HB3 Hose bibb, loose key, vandal resistant, locked door with hose threaded outlet/VB^{1 2}
- IAP In-ground anchor plate
- LOGO Customer specified logo
- LSR Bowl with Leaf and Debris Strainer¹
- MO Bottle filler operated by pushbutton only (Standard with freeze-resistant valves)
- PF Pet fountain¹
- SK10 Cane Detection Skirt (for Non-ADA arm)¹

Product Warranty

WARNING: Cancer and Reproductive Harm - www.P65Warnings.ca.gov

IMPORTANT: INSTALLATION AND SITE PREP FOR FREEZE RESISTANT OPTIONS "-FRU" WILL DIFFER FROM STANDARD. REFER TO DESIGNATED FREEZE RESISTANT INSTALLATION DETAILS.

GY Series

MODEL GYQ84
PEDESTAL MOUNTED BOTTLE FILLER
WITH BI-LEVEL DRINKING FOUNTAIN

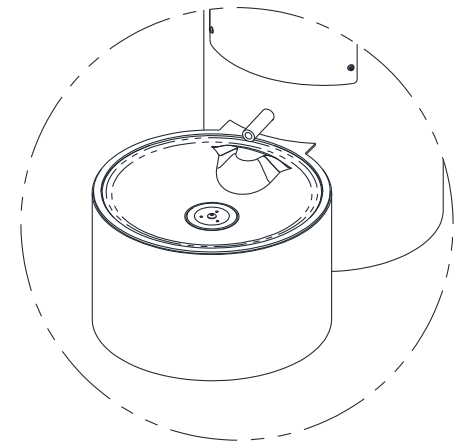
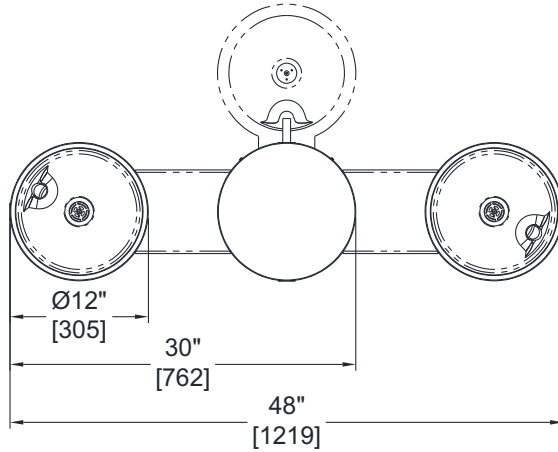

**OPTIONAL -PF
PET FOUNTAIN
DETAIL**

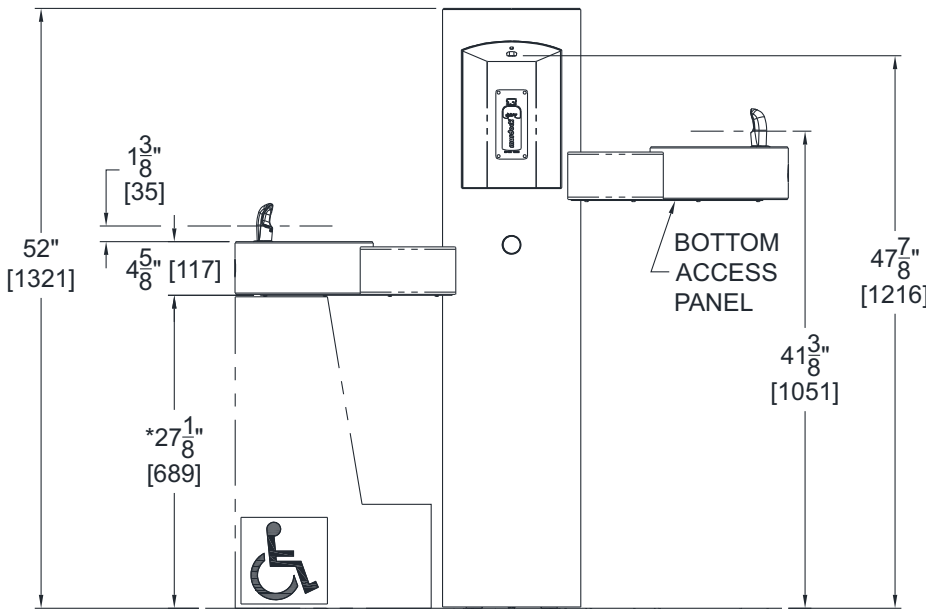

***NOTE:** For -CH30 Option dimension becomes 24" [610].

ANCHORS PROVIDED

1/2" NPT SUPPLY INLET FLEXIBLE CONNECTION

BOTTOM ACCESS PANEL

* Valve specifications:
Minimum/Maximum Pressure
30 PSI to 100 PSI.

**SELECTION SUMMARY
& APPROVAL FOR
MANUFACTURING**

Model Number & Options _____ Quantity _____

Company _____

Contact _____ Title _____

Signature (Approval for Manufacturing) _____ Date _____

All dimensions are subject to manufactures tolerance of plus or minus 1/4" nominal and subject to change without notice. Murdock[®] assumes no responsibility for use of void or superseded data. Dimensions may change with the addition of optional accessories. Murdock[®] Mfg., Member of Morris Group International[®]. Please visit www.murdockmfg.com for most current specifications.