



# BI-LEVEL VANDAL RESISTANT FOUNTAIN, NON - REFRIGERATED & VANDAL RESISTANT MECHANICAL BOTTLE FILLER MODEL PGVMVBFSL

## Suggested Specification

Model PGVMVBFSL is a non-refrigerated drinking fountain and delivers ambient water. Shall include a vandal resistant bottle filler with vandal resistant electro-mechanical push button activation and laminar flow, each fountain shall have a single vandal resistant push button to activate the manual flow of water for the cooler. All bottle filler exterior cabinet and drip tray shall be 18 gauge stainless steel. Key bottle filler components contain Freshield®, which utilizes a silver-based antimicrobial compound to protect the surfaces from discoloration, odors and degradation caused by the growth of micro-organisms and mildew. Basin shall be designed to eliminate splashing and standing water. Vandal Resistant water saver bubbler to reduce waste water by 50% and shall have flexible guard and operate between 20 and 100 PSI. One-piece vandal resistant metal bubbler keyed into place to prevent vandalism. Cabinet finish shall be brushed stainless steel. Cabinet shall have perforated galvanized steel screens to prevent objects from being inserted into the cooler. Shall comply with ANSI 117.1 and ADA. Shall be listed by Underwriters Laboratories to US and Canadian standards. Shall comply with NSF/ANSI 61 and NSF/ANSI 372.

- |                  |  |
|------------------|--|
| <b>Features:</b> | <ul style="list-style-type: none"> <li>• Universal design: high right or high left</li> <li>• Built-in 100 micron strainer stops particles before they enter the waterway</li> <li>• Waterways are lead-free in materials &amp; construction</li> <li>• Vandal resistant metal water saver bubbler</li> <li>• Vandal resistant mechanical front push button on bottle filler and fountains</li> <li>• Vandal resistant fasteners on bottle filler and fountains</li> <li>• Galvanized steel louver and bottom screens</li> <li>• Stainless steel top and heavy duty galvanized steel frame</li> <li>• Includes integral self-scouring waste drain</li> <li>• Ample space within the bottle filler cabinet to add filtration</li> <li>• Access through the top of the bottle filler for clean and easy replacement of filters with Tilt 'N Tether</li> <li>• Logos permanently formed into stainless steel wrapper</li> </ul> |
|------------------|--|

<b>Filtration:</b>	Option to add filtration
<b>Power:</b>	No electricity required
<b>Activation By:</b>	Independent Manual Activation on Bottle Filler and Fountains
<b>Mounting Type:</b>	Wall Mounted
<b>Chilling Option:</b>	Non-Refrigerated
<b>Full Load Amps</b>	0 amps
<b>Rated Watts</b>	0
<b>Approx. Net Weight</b>	56 lbs
<b>Installation Location:</b>	Indoor

MODEL: \_\_\_\_\_ QTY: \_\_\_\_\_

PROJECT: \_\_\_\_\_

CONTACT: \_\_\_\_\_

NOTES: \_\_\_\_\_

APPROVAL: \_\_\_\_\_ DATE: \_\_\_\_\_



**Ships in one box.**

### Installation

- Prior to rough-in consult with local, state and federal codes for proper mounting height
- Shipped with complete instructions and wall mounting bracket
- Removable side and front panels provide easy access for installation

### Finishes

- Standard cabinet finish: Stainless steel

### Limited 1-Year Warranty

(Continental limits of the United States and Canada)  
One year on bottle fillers and electrical components. Detailed warranty certificate enclosed with each water cooler; sample available upon request.

### Export Warranty

One year on components parts. Detailed warranty certificate enclosed with each drinking fountain; sample copy available upon request.

### Certifications/Compliance

- Certified to UL 399 and CAN/CSA C22.2 No.120 (electric water coolers only)
- Product Certified to NSF/ANSI Standard 61-G & 372 and conforms with the lead content requirements for "Lead Free" plumbing as defined by California, Vermont, Maryland, and Louisiana state laws and the U.S. Safe Drinking Water Act
- These water coolers comply with the requirements of ADA (Americans with Disabilities Act) when properly installed



**WARNING:**  
Cancer and Reproductive Harm  
[www.P65Warnings.ca.gov](http://www.P65Warnings.ca.gov)



Specifications subject to change without notice



BI-LEVEL VANDAL RESISTANT FOUNTAIN, NON - REFRIGERATED &  
VANDAL RESISTANT MECHANICAL BOTTLE FILLER  
**MODEL PGVMVBFSL**

**Accessories**



**OASIS VersaFilter III Universal Retrofit Kit**

OASIS Item #041253-001

- Add filtration to your unit - retrofit into all OASIS fountains and bottle fillers. Certified to NSF/ANSI 42 and 53 for lead, Particulate Class I, chlorine, taste and odor reduction to 4,750 gallons.



**Cane apron, Stainless Steel**

OASIS Item #035174-003

- ADA Compliant Apron is needed when water cooler is not installed in an alcove or with right and left wing walls. OASIS Apron is to provide the mandatory 27" to floor ADA requirement.



[View all filters and accessories](#)



BI-LEVEL VANDAL RESISTANT FOUNTAIN, NON - REFRIGERATED &  
 VANDAL RESISTANT MECHANICAL BOTTLE FILLER  
**MODEL PGVMVBFSL**

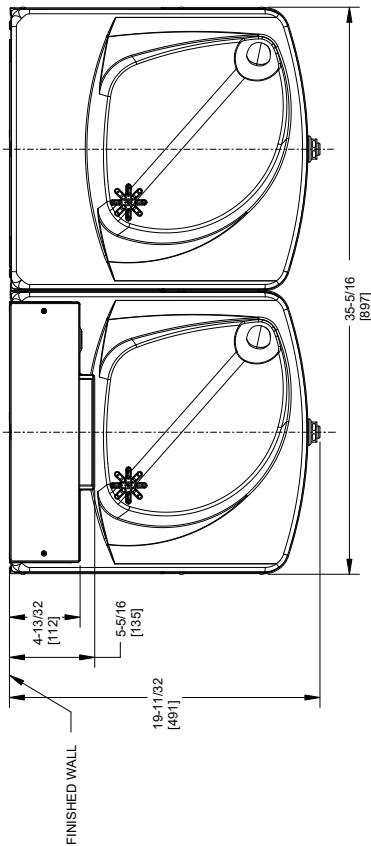

**NOTES.**

1. TRAP, STOP VALVE AND ELECTRICAL OUTLET NOT FURNISHED.
2. ALLOW 4 INCHES [102MM] MIN. PER SIDE FOR VENTILATION.
- \*3. RECOMMENDED ADULT BARRIER FREE HEIGHT INSTALLATION SHOWN. REDUCE HEIGHT BY 3 INCHES FOR INSTALLATIONS USED PRIMARILY BY CHILDREN AGES 12 AND YOUNGER. UNIT SHALL ALSO HAVE A MINIMUM CLEAR FLOOR SPACE 307/60 BY 481/220). ADJUST VERTICAL DIMENSIONS AS REQ'D TO COMPLY WITH FEDERAL, STATE, AND LOCAL CODES.
4. 115V GROUND NORTH AMERICAN DUPLEX RECEPTICAL REQUIRED. THIS DRINKING WATER COOLER IS INTENDED TO BE CONNECTED TO A 20A MINIMUM GROUND FAULT CIRCUIT INTERRUPTING (GFCI) DEVICE TO MEET ALL REQUIREMENTS.
5. ALL DIMENSIONS ARE IN INCHES. DIMENSIONS IN BRACKETS ( ) ARE IN MILLIMETERS.

