



VERSAFILLER® MECHANICAL RETROFIT BOTTLE FILLING STATION KIT, NON-REFRIGERATED, VERSAFILTER III FILTER  
**MODEL PWFSBF-FVF**

**Suggested Specification**

When retrofitted to either the PG8AC or P8AM, the PWFSBF-FVF bottle filler has independent push button manual activation and laminar flow. VersaFiller alcove and cabinet shall be stainless steel. Key plastic components contain Freshield®, which utilizes a silver-based antimicrobial compound to protect the surfaces from discoloration, odors and degradation caused by the growth of micro-organisms and mildew.

When retrofitted to either the PG8AC or P8AM the VersaFiller models satisfy ANSI A117.1 and ADA requirements when properly installed. Units also meet guidelines for children's accessibility providing the floor to orifice height is 30 inches and proper clear floor space is provided for frontal approach. Shall be listed by Underwriters Laboratories to US and Canadian standards. Shall comply with NSF/ANSI 61 and NSF/ANSI 372.

<b>Features:</b>	<ul style="list-style-type: none"> <li>Waterways are lead-free in materials &amp; construction</li> <li>Heavy duty galvanized steel frame</li> <li>Surface mount frame assembly</li> <li>VersaFiller has independent mechanical activation</li> </ul>
	<ul style="list-style-type: none"> <li>Filter located in top bottle filler for easy filter replacement with Tilt 'N Tether</li> <li>Access through the top of the bottle filler for clean and easy replacement of filters with Tilt 'N Tether</li> <li>Logos permanently formed into the alcove and stainless steel wrapper</li> </ul>

<b>Filtration System:</b>	OASIS VersaFilter III, certified to NSF/ANSI 42, 53, 372 and 401 for lead, Particulate Class I, chlorine, taste, odor and microplastics reduction to 4,750 gallons.
---------------------------	---

<b>Activation By:</b>	Independent Manual Activation on Bottle Filler
<b>Mounting Type:</b>	Wall Mounted
<b>Chilling Option:</b>	Utilizes existing refrigeration system if applicable
<b>Approx. Net Weight</b>	18 lbs
<b>Installation Location:</b>	Indoor



**Ships in one box.**

**Installation**

- The PWFSBF VersaFiller is designed to retrofit existing OASIS PG8AC and P8AM pressure cooler models. Units with optional glass fillers must have the glass filler disconnected and removed.
- Prior to rough-in consult with local, state, and federal codes for proper mounting height.
- Shipped with complete instructions and wall mounting brackets.

**Finishes**

- Standard cabinet finish: Stainless steel

**Limited 1-Year Warranty**

(Continental limits of the United States and Canada)  
One year on bottle fillers and electrical components. Detailed warranty certificate enclosed with each water cooler; sample available upon request.

**Export Warranty**

One year on components parts. Detailed warranty certificate enclosed with each drinking fountain; sample copy available upon request.

**Certifications/Compliance**

- Certified to UL 399 and CAN/CSA C22.2 No.120 (electric water coolers only)
- Product Certified to NSF/ANSI Standard 61-G & 372 and conforms with the lead content requirements for "Lead Free" plumbing as defined by California, Vermont, Maryland, and Louisiana state laws and the U.S. Safe Drinking Water Act
- These water coolers comply with the requirements of ADA (Americans with Disabilities Act) when properly installed

MODEL: \_\_\_\_\_ QTY: \_\_\_\_\_  
 PROJECT: \_\_\_\_\_  
 CONTACT: \_\_\_\_\_  
 NOTES: \_\_\_\_\_  
 APPROVAL: \_\_\_\_\_ DATE: \_\_\_\_\_



**WARNING:**  
Cancer and Reproductive Harm  
[www.P65Warnings.ca.gov](http://www.P65Warnings.ca.gov)



Specifications subject to change without notice



VERSAFILLER® MECHANICAL RETROFIT BOTTLE FILLING  
STATION KIT, NON-REFRIGERATED, VERSAFILTER III FILTER  
**MODEL PWFSBF-FVF**

**Accessories**



**Elkay® Adapter Gasket**

OASIS Item #041533-001

- Elkay Adapter Gasket is necessary to complete installation if retrofitting to an Elkay® fountain



**OASIS VersaFilter III Replacement Cartridge**

OASIS Item #041145-001

- Certified to NSF/ANSI 42, 53, 372 and 401 for lead, Particulate Class I, chlorine, taste, odor and microplastics reduction to 4,750 gallons.



[View all filters and accessories](#)



VERSAFILLER® MECHANICAL RETROFIT BOTTLE FILLING STATION KIT, NON-REFRIGERATED, VERSAFILTER III FILTER  
**MODEL PWFSBF-FV**

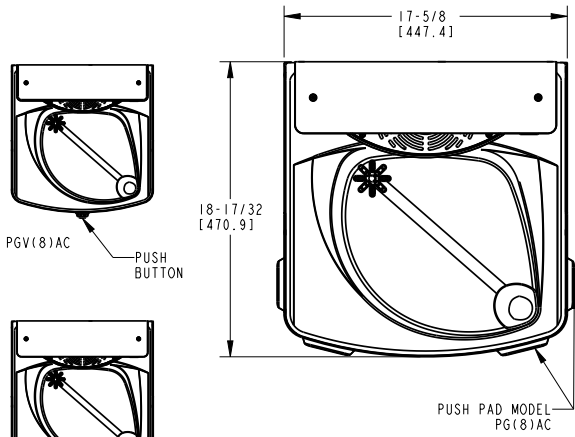

NOTES:

1. TRAP, STOP VALVE AND ELECTRICAL OUTLET NOT FURNISHED.
2. ALLOW 4 INCHES [102MM] MIN. PER SIDE FOR VENTILATION.
3. RECOMMENDED ADULT BARRIER FREE HEIGHT UNINSTALLATION SHOWN. REDUCE HEIGHT BY 3 INCHES FOR INSTALLATIONS USED PRIMARILY BY CHILDREN AGES 12 AND YOUNGER. UNIT SHALL ALSO HAVE A MINIMUM CLEAR FLOOR SPACE 20[760] BY 48[1220]. ADJUST VERTICAL DIMENSIONS AS REQUIRED TO COMPLY WITH FEDERAL, STATE, AND LOCAL CODES.
4. 115V GROUNDED NORTH AMERICAN DUPLEX RECEPTACLE REQUIRED. THIS DRINKING WATER COOLER IS INTENDED TO BE CONNECTED TO A 20A MINIMUM GROUND FAULT CIRCUIT INTERRUPTING (GFCI) DEVICE TO MEET UL REQUIREMENTS.
5. ALL DIMENSIONS ARE IN INCHES. DIMENSIONS IN BRACKETS [ ] ARE IN MILLIMETERS.

ROUGH-IN DRAWING IS SHOWN WITH A PG8ACSL UNIT IN ORDER TO SHOW THE PROPER HEIGHT OF THE UNIT WHEN RETROFITTED TO THE PARENT UNIT AND HEIGHT FROM THE FLOOR IN ORDER TO COMPLY WITH ADA STANDARDS. THE PG8AC UNIT IS NOT INCLUDED WITH THE PURCHASE OF THE PW(F)SBF.

