



We Know Water.

VERSAFILLER® RETROFIT KIT WITH VERSAFILTER™ III

• PWFSBF

Suggested Specification

When retrofitted to either the PG8AC or P8AM, the PWFSBF bottle filler has independent manual activation. Key VersaFiller components and activation button contain Freshield®, which utilizes a silver-based antimicrobial compound to protect the surfaces from discoloration, odors and degradation caused by the growth of micro-organisms and mildew. VersaFiller cabinet finish is brushed stainless steel.

When retrofitted to either the PG8AC or P8AM the VersaFiller models satisfy ANSI A117.1 and ADA requirements when properly installed. Units also meet guidelines for children’s accessibility providing the floor to orifice height is 30 inches and proper clear floor space is provided for frontal approach. Shall be listed by Underwriters Laboratories to US and Canadian standards. Shall comply with NSF/ANSI 61 and NSF/ANSI 372.



Features:	<ul style="list-style-type: none"> Waterways are lead-free in materials & construction VersaFilter III located in top bottle filler for easy filter replacement with Tilt ‘N Tether Heavy duty galvanized steel frame Surface mount frame assembly VersaFiller has independent mechanical activation
Filtration:	VersaFilter III is Certified to NSF/ANSI 42 and 53 for lead, Particulate Class I, chlorine, taste and odor reduction to 4,750 gallons
Power:	115 Volts, 60 Hz
Activation By:	Independent Manual Activation on Bottle Filler
Mounting Type:	Wall Mounted
Chilling Option:	Utilizes existing refrigeration system if applicable
Approx. Net Weight:	8.5 lbs.
Installation Location:	Indoor

The PWFSBF VersaFiller is designed to retrofit existing OASIS PG8AC and P8AM pressure cooler models. Models that this unit will not retro to are the electric eye P8AC and P8AM units. Units with optional glass fillers must have the glass filler disconnected and removed.

Installation

- Prior to rough-in consult with local, state, and federal codes for proper mounting height.
- Shipped with complete instructions and wall mounting brackets.

Finishes

- VersaFiller cabinet finish is brushed stainless steel

Options

- Elkay Adapter Gasket 041114-001
- Sunroc/HAWS Adapter Gasket 036689-101

Limited 1-Year Warranty

(Continental limits of the United States and Canada) One year on components parts. Detailed warranty certificate enclosed with each water cooler; sample available upon request.

Export Warranty

One year on components parts. Detailed warranty certificate enclosed with each drinking fountain; sample copy available upon request.

Certifications/Compliance

- Certified to UL 399 and CAN/CSA C22.2 No.120 (electric water coolers only)
- Product Certified to NSF/ANSI Standard 61-G & 372 and conforms with the lead content requirements for “Lead Free” plumbing as defined by California, Vermont, Maryland, and Louisiana state laws and the U.S. Safe Drinking Water Act
- These water coolers comply with the requirements of ADA (Americans with Disabilities Act) when properly installed



WARNING:
Cancer and Reproductive Harm
www.P65Warnings.ca.gov



Specifications subject to change without notice

OASIS® PWFSBF VERSAFILLER WITH VERSAFILTER™ III RETROFIT KIT

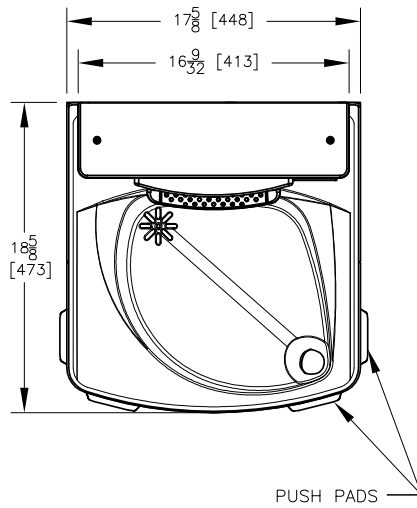

NOTES:

1. TRAP, STOP VALVE AND ELECTRICAL OUTLET NOT FURNISHED.
2. ALLOW 4 INCHES [102 MM] MIN. PER SIDE FOR VENTILATION.
- *3. RECOMMENDED ADULT BARRIER FREE HEIGHT INSTALLATION SHOWN. REDUCE HEIGHT BY 3 INCHES FOR INSTALLATIONS USED PRIMARILY BY CHILDREN AGES 12 AND YOUNGER. UNIT SHALL ALSO HAVE A MINIMUM CLEAR FLOOR SPACE 30[760] BY 48[1220]. ADJUST VERTICAL DIMENSIONS AS REQ'D TO COMPLY WITH FEDERAL, STATE, AND LOCAL CODES.
4. 115v GROUNDED NORTH AMERICAN DUPLEX RECEPTACLE REQUIRED. THIS DRINKING WATER COOLER IS INTENDED TO BE CONNECTED TO A 20A MINIMUM GROUND FAULT CIRCUIT INTERRUPTING (GFCI) DEVICE TO MEET UL REQUIREMENTS.
5. ALL DIMENSIONS ARE IN INCHES. DIMENSIONS IN BRACKETS [] ARE IN MILLIMETERS.

ROUGH-IN DRAWING IS SHOWN WITH A PG8AC UNIT IN ORDER TO SHOW THE PROPER HEIGHT OF THE UNIT WHEN RETROFITTED TO THE PARENT UNIT AND HEIGHT FROM THE FLOOR IN ORDER TO COMPLY WITH ADA STANDARDS. THE PG8AC UNIT IS NOT INCLUDED WITH THE PURCHASE OF THE PW(F)SBF.

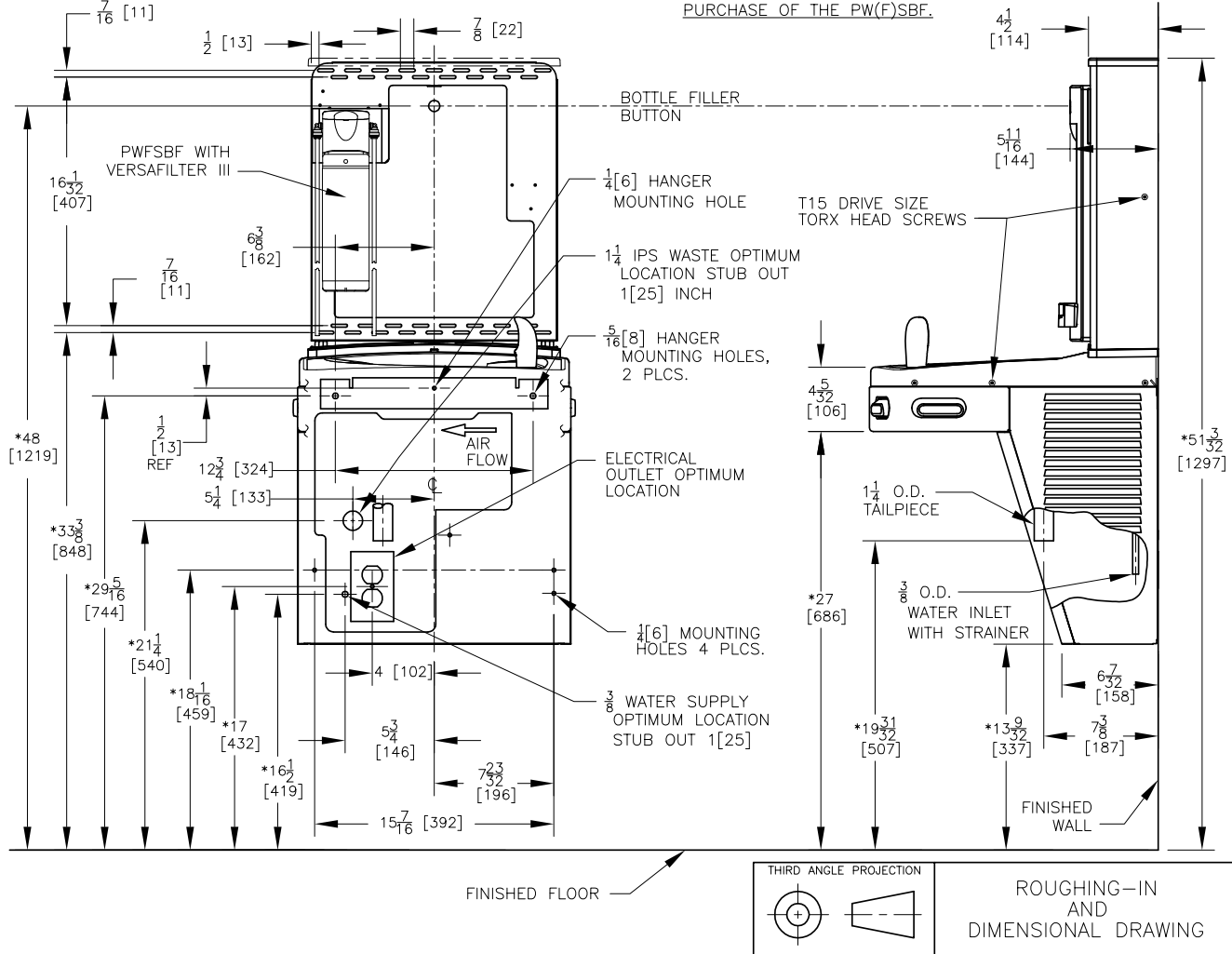

THIRD ANGLE PROJECTION

ROUGHING-IN AND DIMENSIONAL DRAWING