



# OUTDOOR VANDAL RESISTANT RETROFIT BOTTLE FILLING STATION KIT, ELECTRO-MECHANICAL MODEL PWSVDBF

## Suggested Specification

When retrofitted to either the PG8AC or P8AM, the PWSVDBF bottle filler has independent electro-mechanical push button activation and laminar flow. All exterior bottle filler cabinet and drip tray shall be 18 gauge stainless steel. Key plastic components contain Freshield®, which utilizes a silver-based antimicrobial compound to protect the surfaces from discoloration, odors and degradation caused by the growth of micro-organisms and mildew. Unit shall include filter monitor and bottle counter. When retrofitted to either the PG8AC or P8AM the bottle filler model satisfies ANSI A117.1 and ADA requirements when properly installed. Units also meet guidelines for children's accessibility providing the floor to orifice height is 30 inches and proper clear floor space is provided for frontal approach. Shall be listed by Underwriters Laboratories to US and Canadian standards. Shall comply with NSF/ANSI 61 and NSF/ANSI 372.

<b>Features:</b>	• Waterways are lead-free in materials & construction
	• Heavy duty galvanized steel frame
	• Manual solenoid activation bottle filler
	• Ample space within the bottle filler cabinet to add filtration
	• Access filtration through the top of the bottle filler for clean and easy replacement of filters with Tilt 'N Tether
• Built-in filter monitor and bottle counter	
• Logos permanently formed into the alcove and stainless steel wrapper	
• Surface mount frame assembly	
<b>Filtration</b>	Utilizes existing filtration if applicable. Option to add filtration to top of bottle filler.*
<b>Power:</b>	115 Volts, 60 Hz
<b>Activation By:</b>	Manual Electro-Mechanical Activation
<b>Mounting Type:</b>	Wall Mounted
<b>Chilling Option:</b>	Utilizes existing refrigeration system if applicable
<b>Full Load Amps:</b>	0.2
<b>Rated Watts:</b>	11
<b>Approx. Net Weight:</b>	15.5 lbs.
<b>Installation Location:</b>	Indoor/Outdoor

The PWSVDBF is designed to retrofit existing OASIS PG8AC and P8AM pressure cooler models. Units with optional glass fillers must have the glass filler disconnected and removed.

MODEL: \_\_\_\_\_ QTY: \_\_\_\_\_  
 PROJECT: \_\_\_\_\_  
 CONTACT: \_\_\_\_\_  
 NOTES: \_\_\_\_\_  
 APPROVAL: \_\_\_\_\_ DATE: \_\_\_\_\_



**Ships in one box.**

### Installation

- Prior to rough-in consult with local, state, and federal codes for proper mounting height.
- Shipped with complete instructions and wall mounting brackets.

### Finishes

- VersaFiller cabinet finish is stainless steel

### Limited 1-Year Warranty

(Continental limits of the United States and Canada)  
 One year on bottle fillers and electrical components. Detailed warranty certificate enclosed with each water cooler; sample available upon request.

### Export Warranty

One year on component parts. Detailed warranty certificate enclosed with each drinking fountain; sample copy available upon request.

### Certifications/Compliance

- Certified to UL 399 and CAN/CSA C22.2 No.120 (electric water coolers only)
- Product Certified to NSF/ANSI Standard 61-G & 372 and conforms with the lead content requirements for "Lead Free" plumbing as defined by California, Vermont, Maryland, and Louisiana state laws and the U.S. Safe Drinking Water Act
- These water coolers comply with the requirements of ADA (Americans with Disabilities Act) when properly installed

When used or stored in non-temperature controlled environments, the unit must be adequately winterized and/or protected from extreme heat to prevent damage.

\*Ensure filters are certified for outdoor use.



**WARNING:**  
 Cancer and Reproductive Harm  
[www.P65Warnings.ca.gov](http://www.P65Warnings.ca.gov)



Specifications subject to change without notice



# OUTDOOR VANDAL RESISTANT RETROFIT BOTTLE FILLING STATION KIT, ELECTRO-MECHANICAL MODEL PWSVDBF

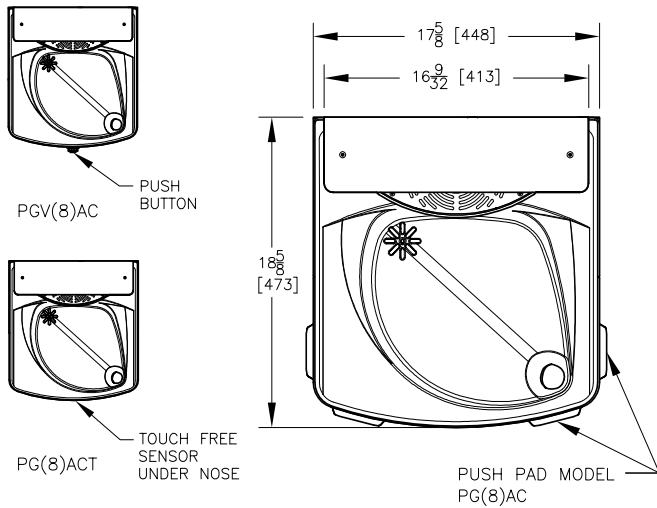

**NOTES:**

1. TRAP, STOP VALVE AND ELECTRICAL OUTLET NOT FURNISHED.
2. ALLOW 4 INCHES [102 MM] MIN. PER SIDE FOR VENTILATION.
- \*3. RECOMMENDED ADULT BARRIER FREE HEIGHT INSTALLATION SHOWN. REDUCE HEIGHT BY 3 INCHES FOR INSTALLATIONS USED PRIMARILY BY CHILDREN AGES 12 AND YOUNGER. UNIT SHALL ALSO HAVE A MINIMUM CLEAR FLOOR SPACE 30[760] BY 48[1220]. ADJUST VERTICAL DIMENSIONS AS REQ'D TO COMPLY WITH FEDERAL, STATE, AND LOCAL CODES.
4. 115v GROUNDED NORTH AMERICAN DUPLEX RECEPTACLE REQUIRED. THIS DRINKING WATER COOLER IS INTENDED TO BE CONNECTED TO A 20A MINIMUM GROUND FAULT CIRCUIT INTERRUPTING (GFCI) DEVICE TO MEET UL REQUIREMENTS.
5. ALL DIMENSIONS ARE IN INCHES. DIMENSIONS IN BRACKETS [ ] ARE IN MILLIMETERS.

